

[Http://www.parsun.com.cn](http://www.parsun.com.cn)

PARSUN

百勝

零件目錄

PARTS CATALOGUE

F2.6 BM

蘇州百勝動力機器有限公司

SUZHOU PARSUN POWER MACHINE CO., LTD

目录

CONTENTS

控制系统	1~2
CONTROL	1~2
托架	3~4
BRACKET	3~4
操舵系统	5~6
STEERING	5~6
水上装置壳体	7~8
UPPER CASING	7~8
水下装置壳体和驱动系统1	9~10
LOWER CASING & DRIVE 1	9~10
水下装置壳体和驱动系统 2	11~12
LOWER CASING & DRIVE 2	11~12
点火系统	13
IGNITION ASS'Y	13
气缸和曲轴箱1	14~15
CYLINDER & CRANKCASE 1	14~15
曲轴和活塞	16
CRANKSHAFT & PISTON	16
凸轮轴和阀门	17
CAMSHAFT & VALVE	17
气缸和曲轴箱2	18~19
CYLINDER & CRANKCASE 2	18~19
燃油系统	20~21
FUEL	20~21
进气系统	22
INTAKE	22
起动机组件	23
STARTER	23
底罩	24
BOTTON COWLING	24
顶罩	25
TOP COWLING	25
修理件1	26~27
REPAIRE KIT 1	26~27
修理件2	28~29
REPAIRE KIT 2	28~29

零部件名称:

控制系统

PARTS NAME:

CONTROL

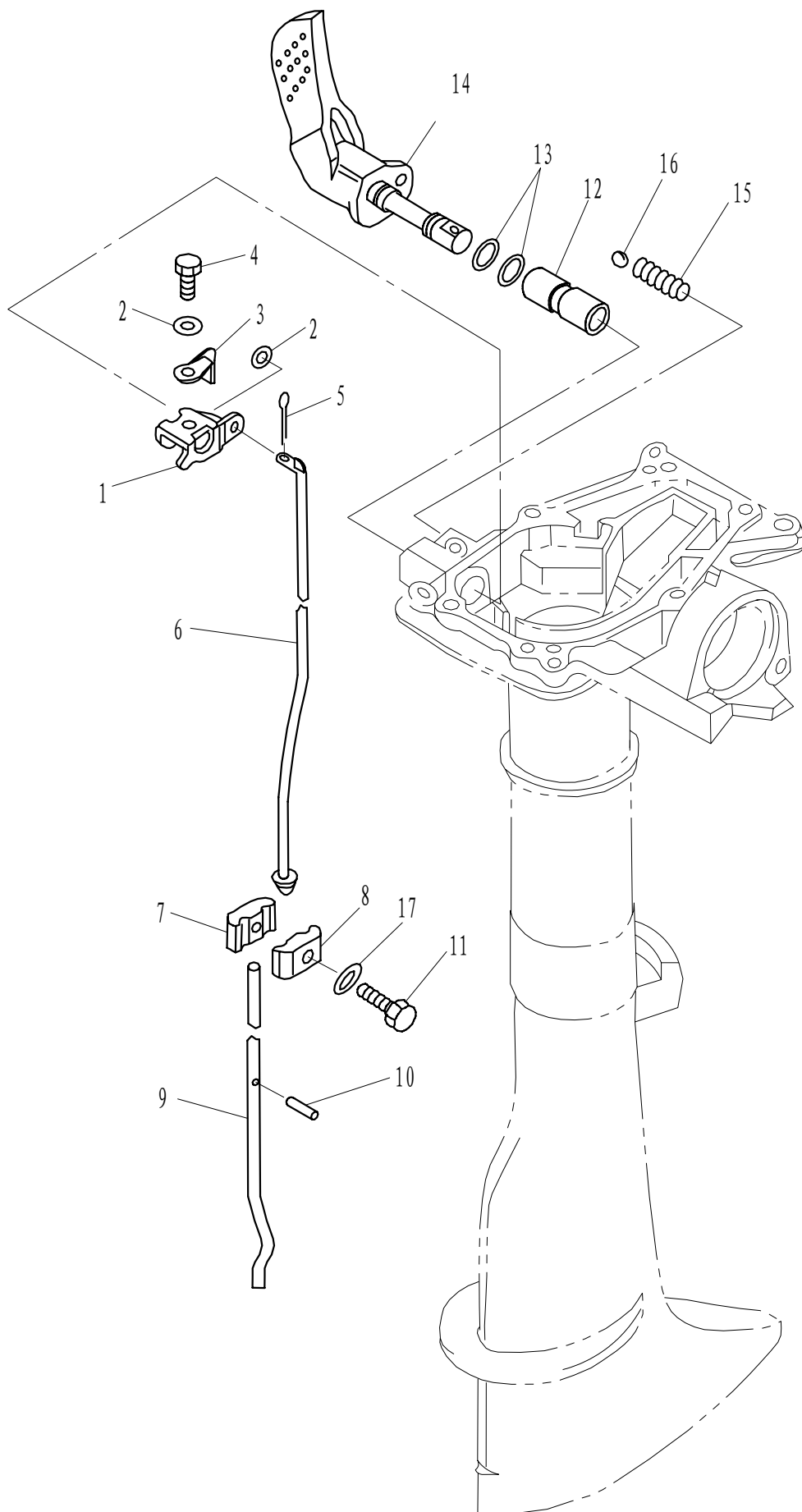

零部件名称:

托架

PARTS NAME:

BRACKET

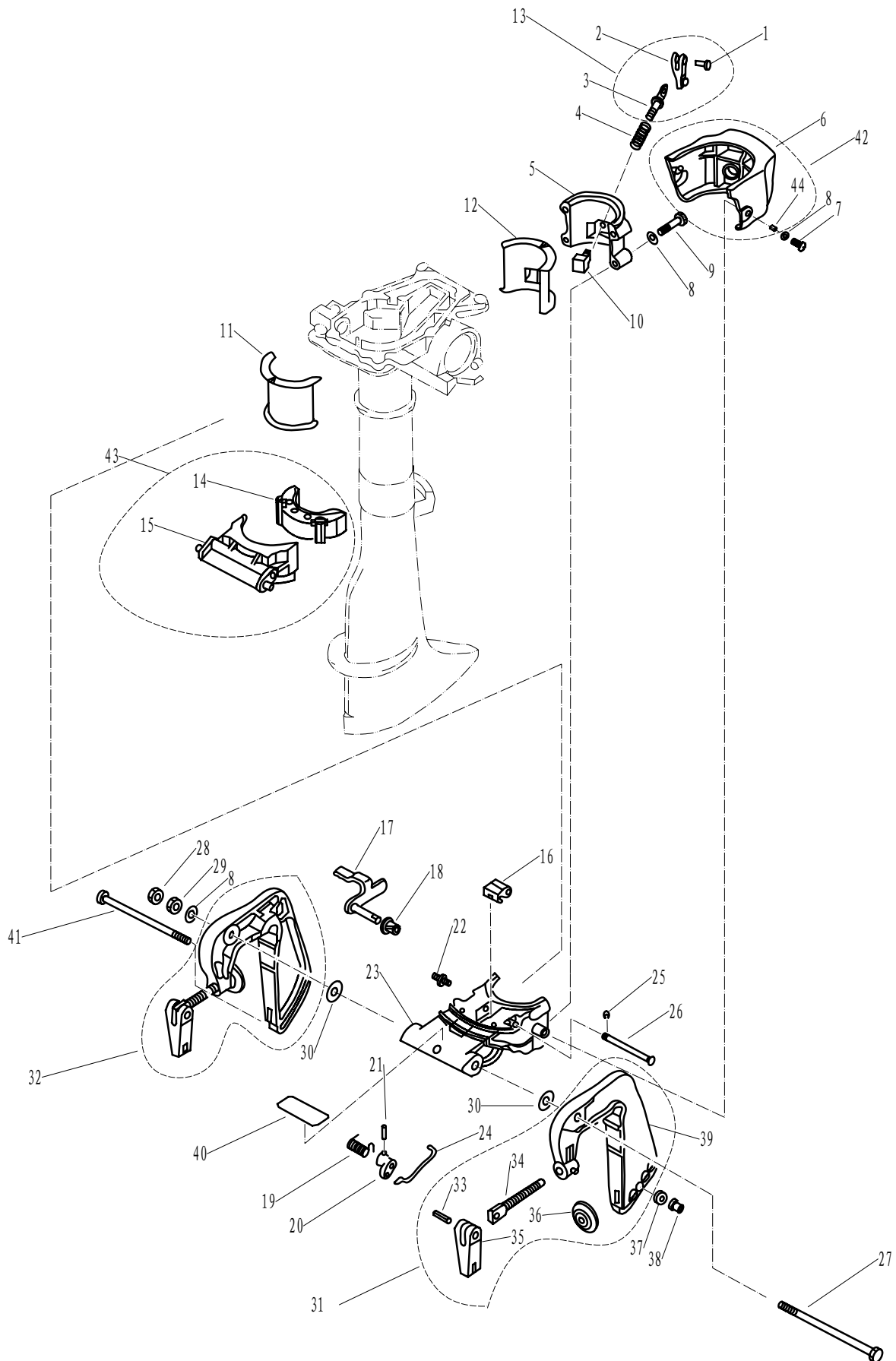

SN. 参照号码	PART NO. 零件编号	DESCRIPTION 零件名称 (中文)	DESCRIPTION 零件名称 (英文)	QTY 数量				REMARKS 备注
1	GB/T875-86	扁平头半空心铆钉4×11	RIVET	1				
2	F4-01060002	锁紧手柄	CLAMP HANDLE	1				

零部件名称:

托架

PARTS NAME:

BRACKET

SN. 参照号码	PART NO. 零件编号	DESCRIPTION 零件名称(中文)	DESCRIPTION 零件名称(英文)	QTY 数量					REMARKS 备注
3	F2.6-01050101	锁紧手柄螺杆	LOCKED SCREW	1					
4	F2.6-01050002	压缩弹簧	SPRING	1					
5	F2.6-01050001	旋转支架盖	COVER, SWIVEL BRACKET	1					
6	F2.6-00000101	托架护盖	COVER, BRACKET	1					
7	GB/T818-2000	十字槽盘头螺钉M6x16	SCREW, PAN HEAD	2					
8	GB/T97.1-85	平垫圈6	WASHER	6					
9	GB/T5783-2000	六角螺栓M6x30	BOLT	4					
10	F2.6-01050200	锁紧块组件	LOCKED BLOCK ASSY	1					
11	F2.6-01000003	旋转支架衬套A	BUSHING A	1					
12	F2.6-01000004	旋转支架衬套B	BUSHING B	1					
13	F2.6-01050100	锁紧手柄组件	LOCKED HANDLE ASSY	1					
14	F2.6-01040100	承推减震器	DAMPER	1					
15	F2.6-01040001	承推托架	BRACKET , THRUST RECEIVE	1					
16	F2.6-01030007	起翘块	LEVER	1					
17	F2.6-01030100	角度锁紧手柄组件	TILT CLAMP HANDLE ASSY	1					
18	F4-01090006	衬套	BUSHING	1					
19	F2.6-01030003	角度锁紧手柄钮簧	SPRING	1					
20	F2.6-01030004	角度定位件	LEVER, TILT LOCK	1					
21	GB/T879.2-2000	轻型直槽弹性圆柱销Φ2x10	PIN	1					
22	GB/T7940.1-95	直通式压注油杯M6	NIPPLE, GREASE	1					
23	F2.6-01030001	旋转支架座	BRACKET, SWIVEL	1					
24	F2.6-01030005	定位件连杆	ROD, TILT LOCK	1					
25	GB/T896-86	开口档圈3.5	CLIP	1					
26	F2.6-01030006	起翘块销轴	PIN	1					
27	F2.6-01000001	六角螺栓M8x135	BOLT	1					
28	GB/T6172.1-85	六角薄螺母M8	NUT	1					
29	GB/T6170-85	六角螺母M8	NUT	1					
30	GB/T96-1985	大垫圈8	WASHER	2					
31	F2.6-01010000	左夹紧托架组件	BRACKET LEFT ASSY	1					
32	F2.6-01020000	右夹紧托架组件	BRACKET RIGHT ASSY	1					
33	F4-01010005	舰板夹紧手柄铆钉	RIVET	2					
34	F4-01010002	舰板夹紧螺杆	CLAMP BOLT	2					
35	F4-01010004	舰板夹紧手柄	CLAMP SHIPBOARD HANDLE	2					
36	F4-01010003	舰板夹紧圆盘	CLAMP PLATE	2					
37	F2.6-01000002	螺栓垫管	BUSH , BOLT	1					
38	GB/T889.1-2000	非金属嵌件六角锁紧螺母M6	NUT	1					
39	F2.6-01010001	左夹紧托架	BRACKET, CLAMP (LEFT)	1					
40	F2.6-07000009	标贴9	MARK 9	1					
41	GB/T5782-2000	六角螺栓M6 × 125	BOLT	1					
42	F2.6-00000100	托架护盖组件	BRACKET COVER ASSY	1					
43	F2.6-01040000	承推托架组件	THRUST RECEIVE ASSY	1					
44	F2.6-00000102	护盖衬管	BUSH	1					

零部件名称: 操舵系统

PARTS NAME: STEERING

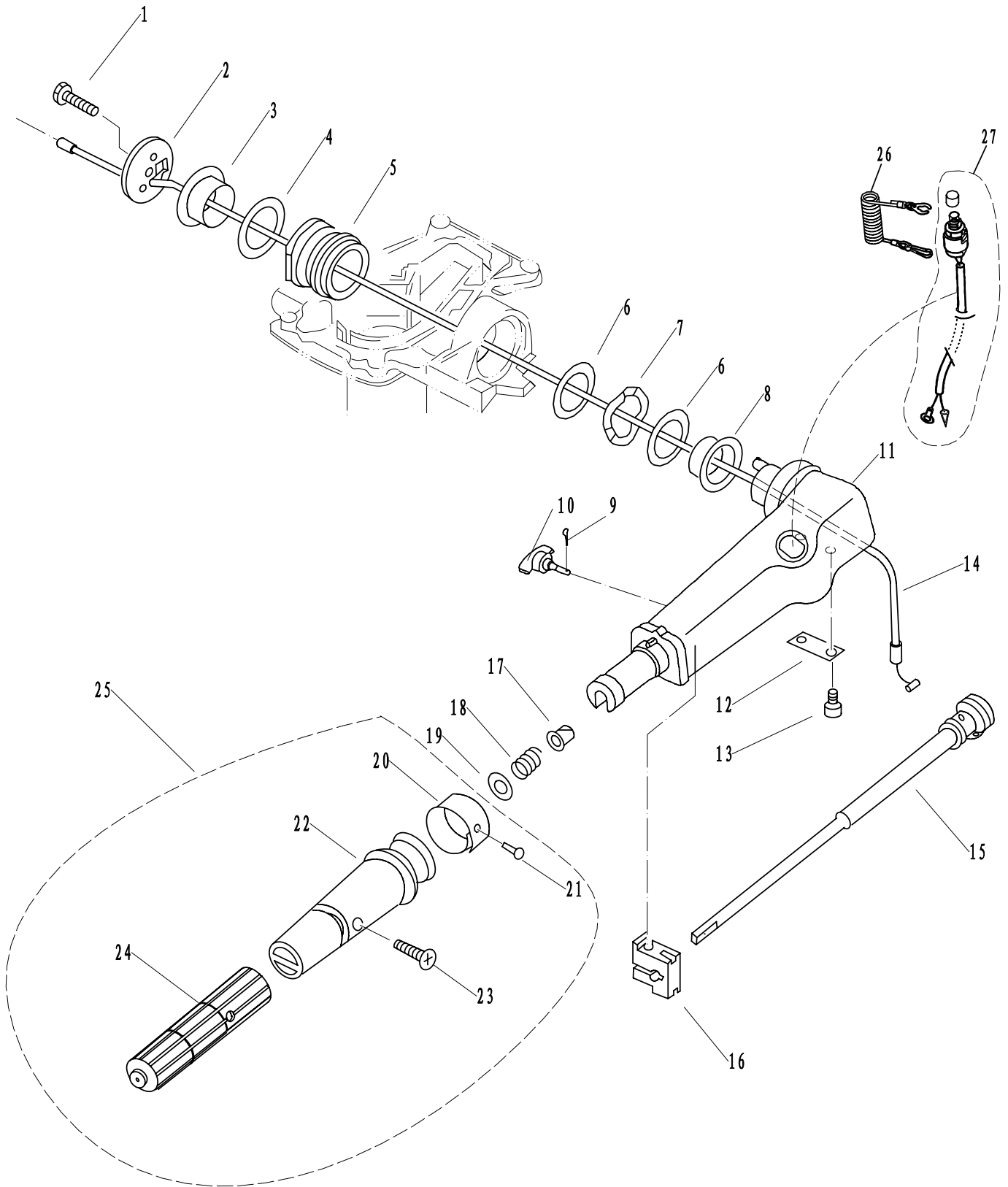

零部件名称: 水上装置壳体

PARTS NAME: UPPER CASING

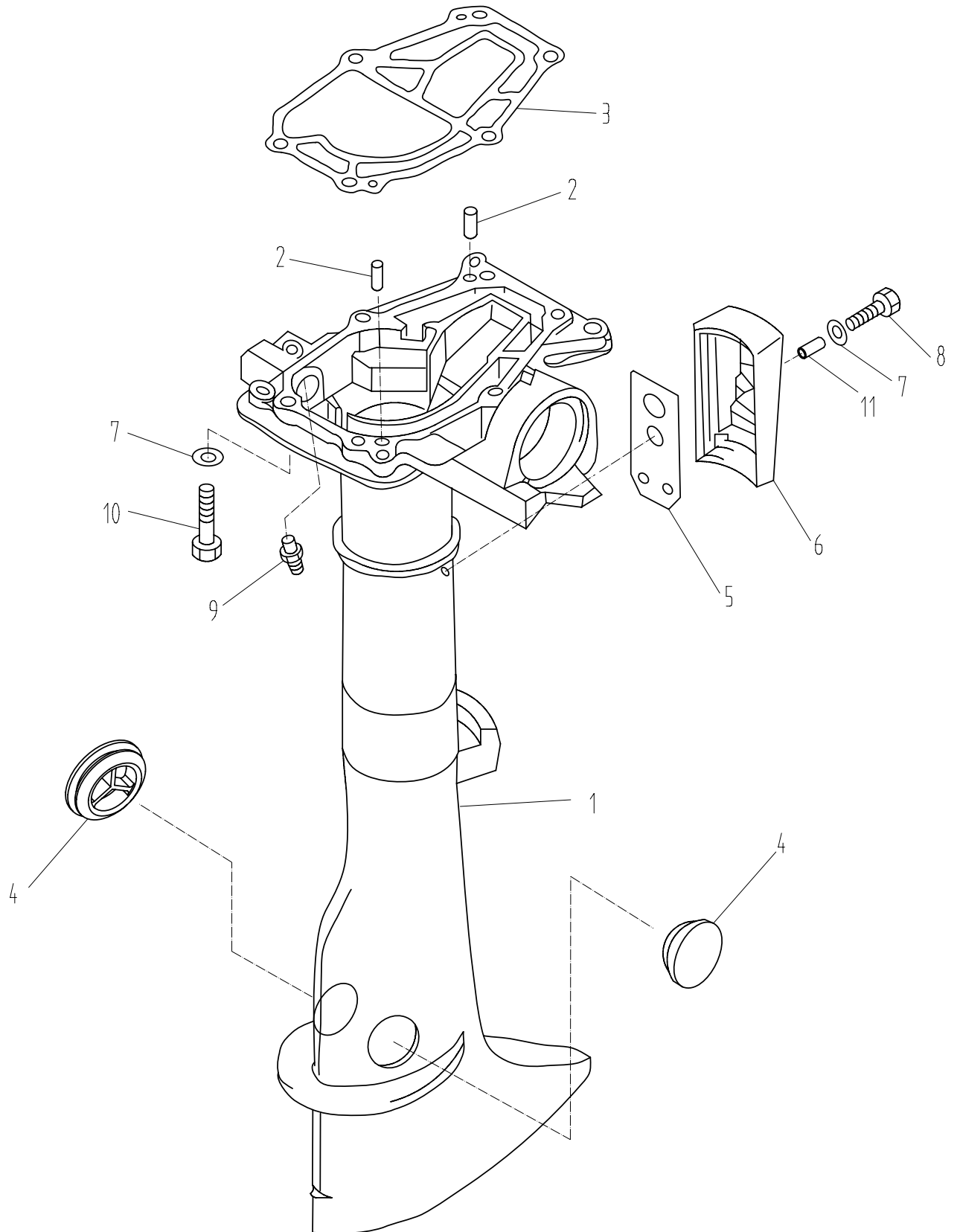

零部件名称: 水下装置壳体 and 驱动系统1

PARTS NAME: LOWER CASING & DRIVE 1

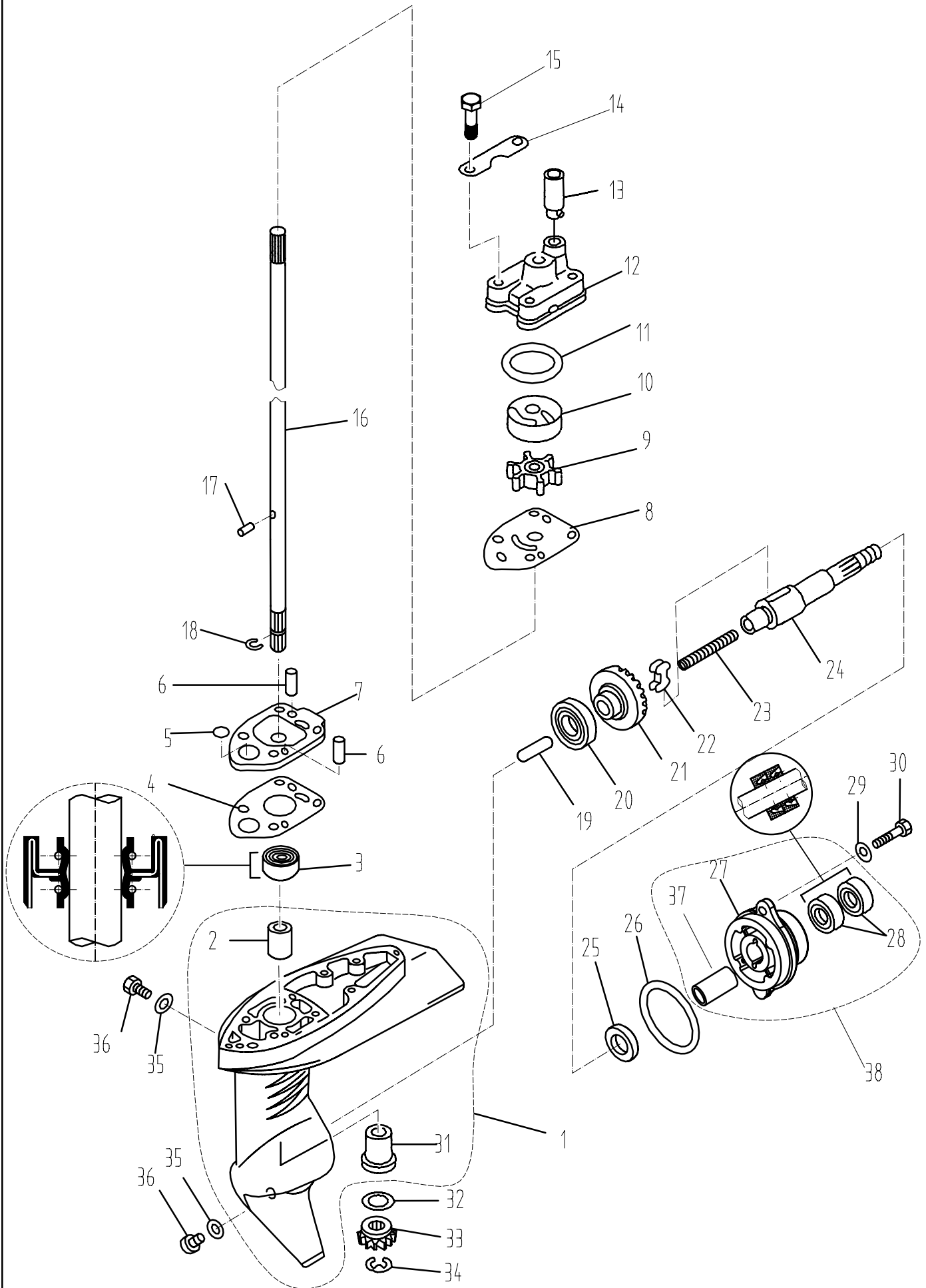

零部件名称: 水下装置壳体 and 驱动系统2

PARTS NAME: LOWER CASING & DRIVE 2

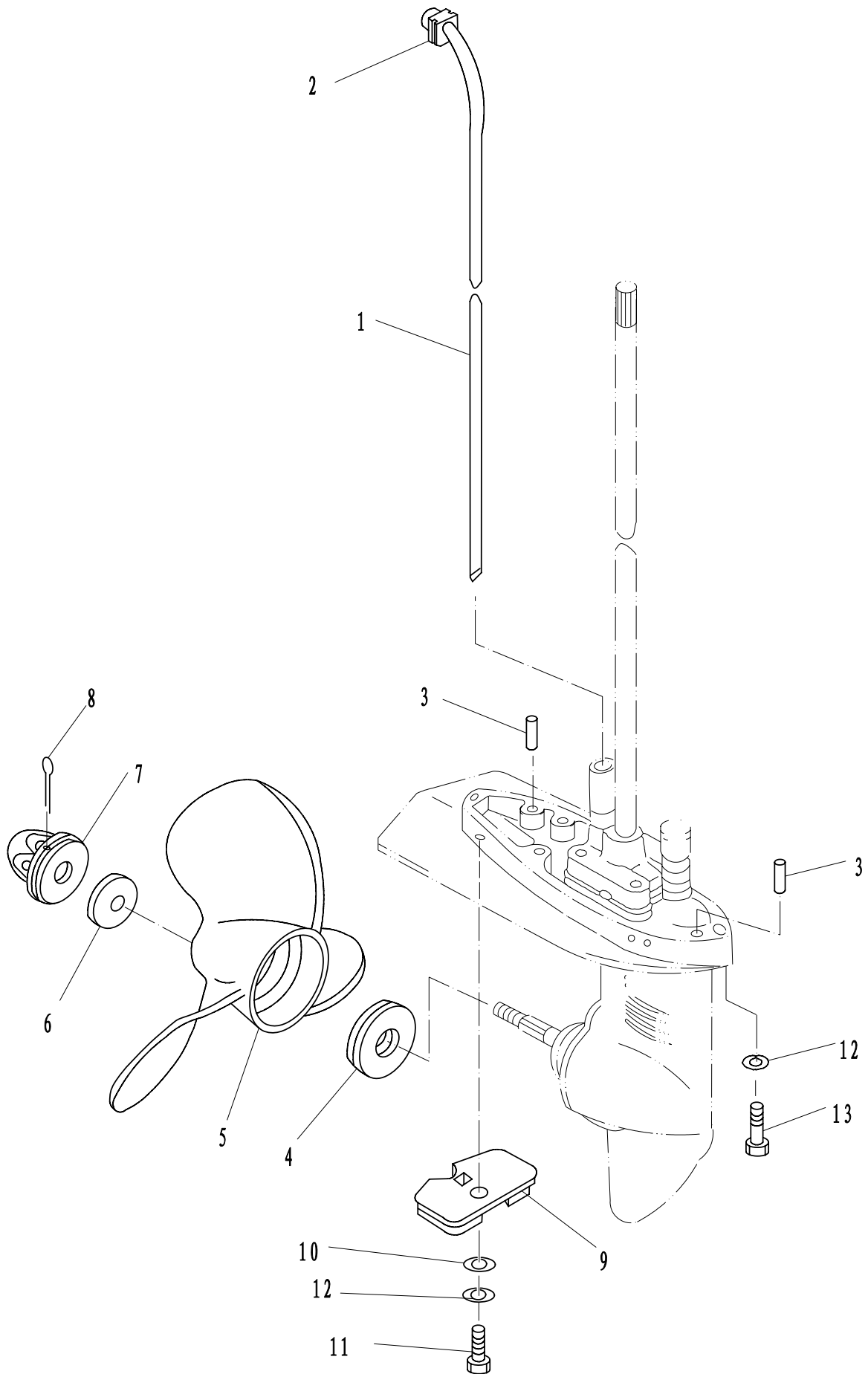

零部件名称:

汽缸 & 曲轴箱1

PARTS NAME:

CYLINDER & CRANKCASE 1

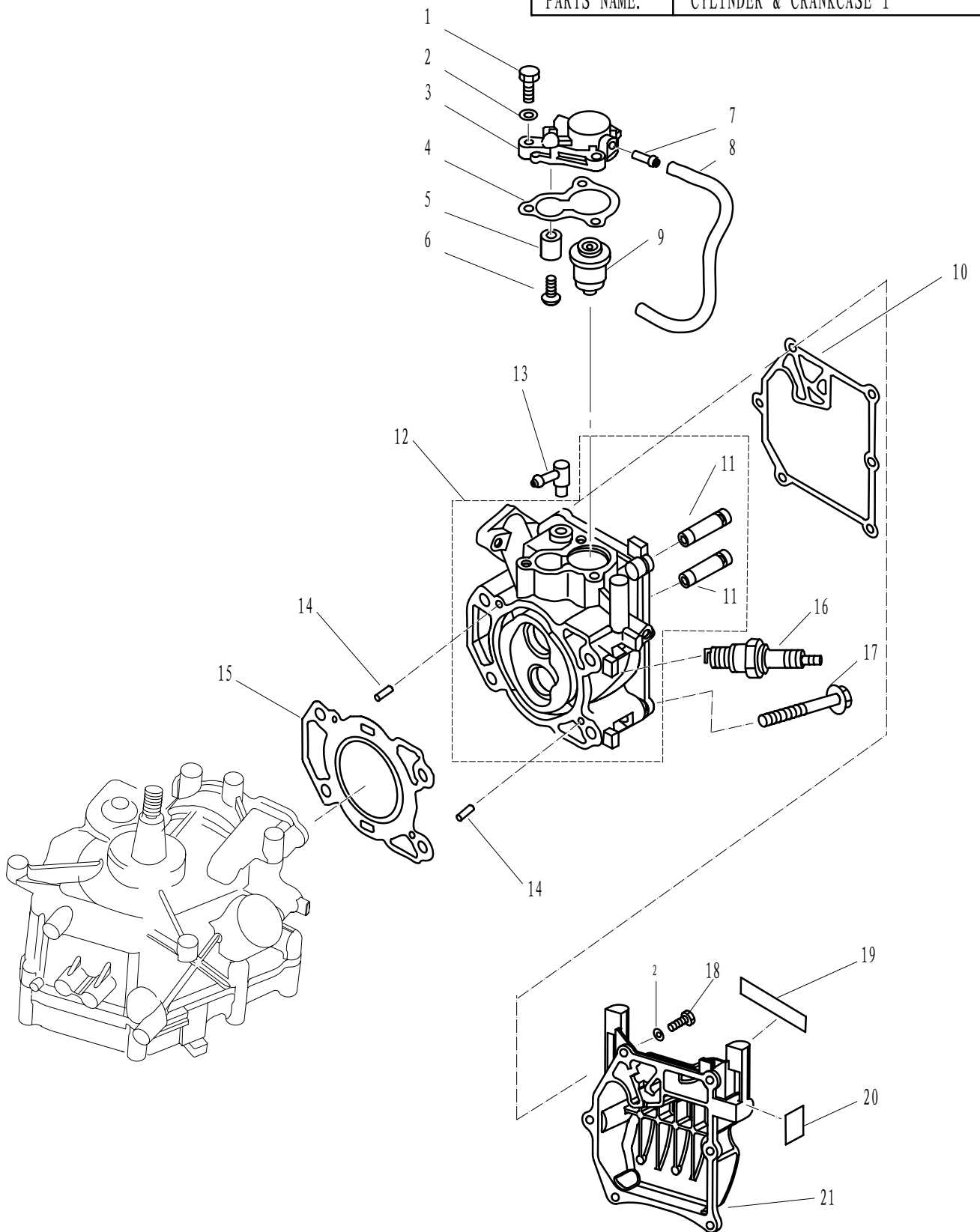

零部件名称:

汽缸和曲轴箱 2

PARTS NAME:

CYLINDER & CRANKCASE 2

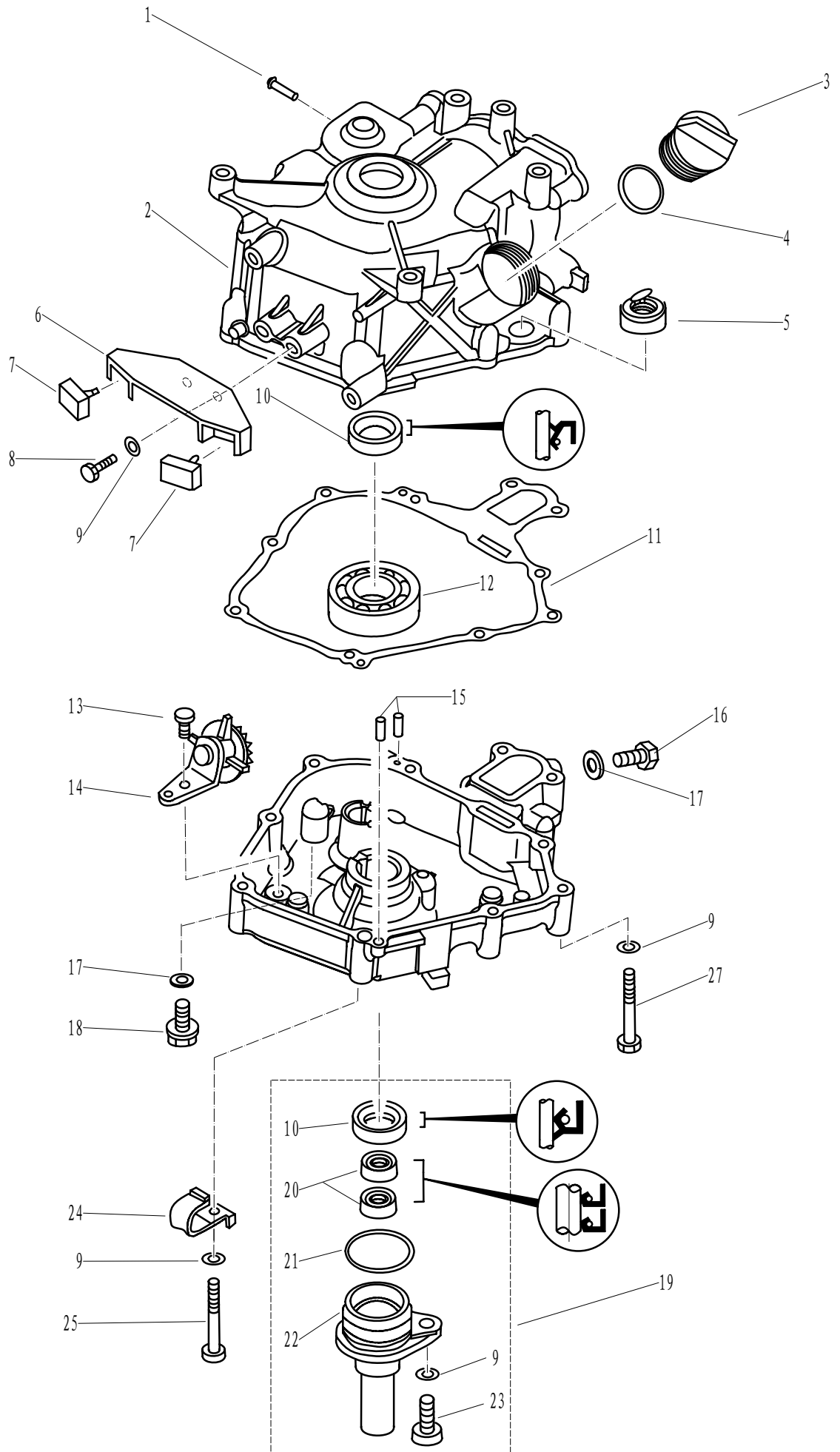

零部件名称:

燃油系统

PARTS NAME:

FUEL

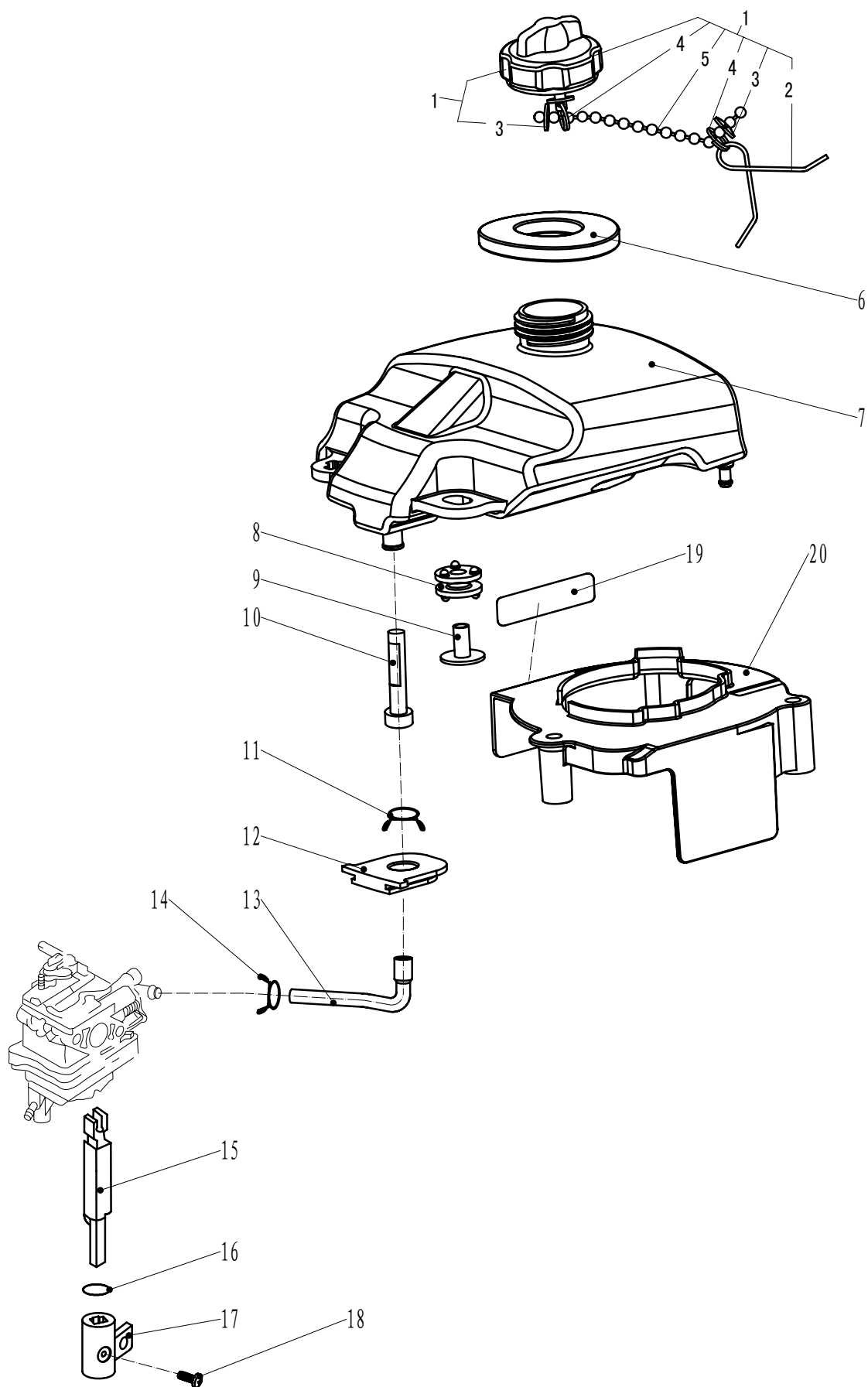

零部件名称:	底罩
PARTS NAME:	BOTTOM COWLING

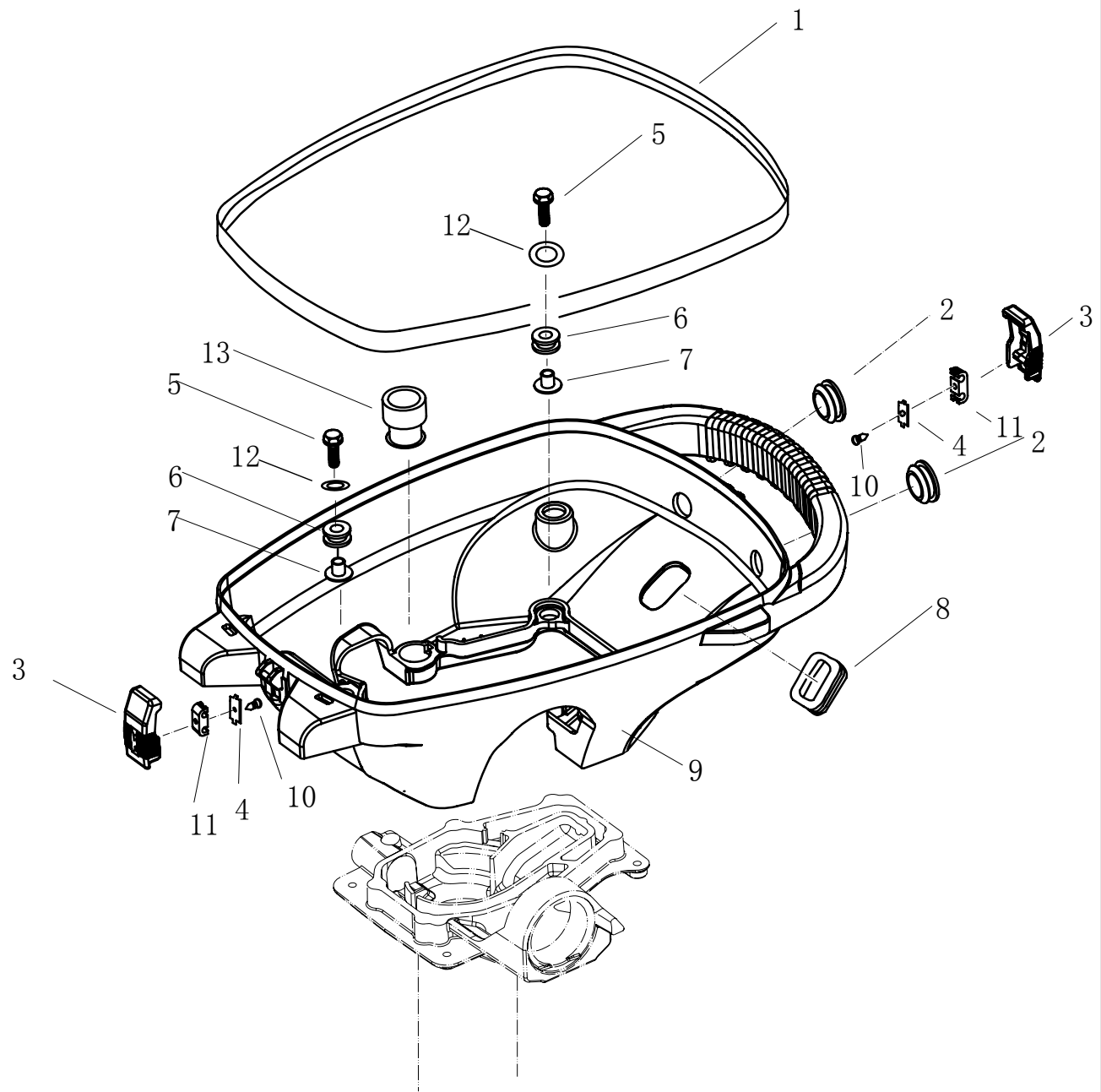

SN. 参照号码	PART NO. 零件编号	DESCRIPTION 零件名称(中文)	DESCRIPTION 零件名称(英文)	QTY 数量					REMARKS 备注
1	F2.6-05000002	底罩密封条	SEAL, BOTTOM COWLING	1					
2	F2.6-05000004	圆形闷头	RUBBER PLUG, CIRCULAR	2					
3	F2.6-05000008	顶罩锁紧钩	HOOK, LOCKING	2					
4	F2.6-05000010	金属连接杆	METALLIC LINK ROD	2					
5	GB/T5783-2000	六角螺栓M6X25	BOLT	4					
6	F2.6-05000006	底罩减震圈	DAMPER	4					
7	F2.6-05000007	凸缘垫管	TUBE FLANGE	4					
8	F2.6-05000003	长方形橡胶闷头	RUBBER PLUG, QUADRATE	1					
9	F2.6-05000001	底罩	BOTTOM COWLING	1					
10	GB/T845-85	十字槽盘头自攻螺钉ST2.9X5	SCREW, TAPPING	2					
11	F2.6-05000009	锁紧钩连接件	CONNECTER-ROD	2					
12	GB/T96-85	平垫圈6	WASHER 6	4					
13	F2.6-05000005	放油口胶套	RUBBER LOVER	1					

零部件名称:

修理套件 1

PARTS NAME:

REPAIR KIT 1

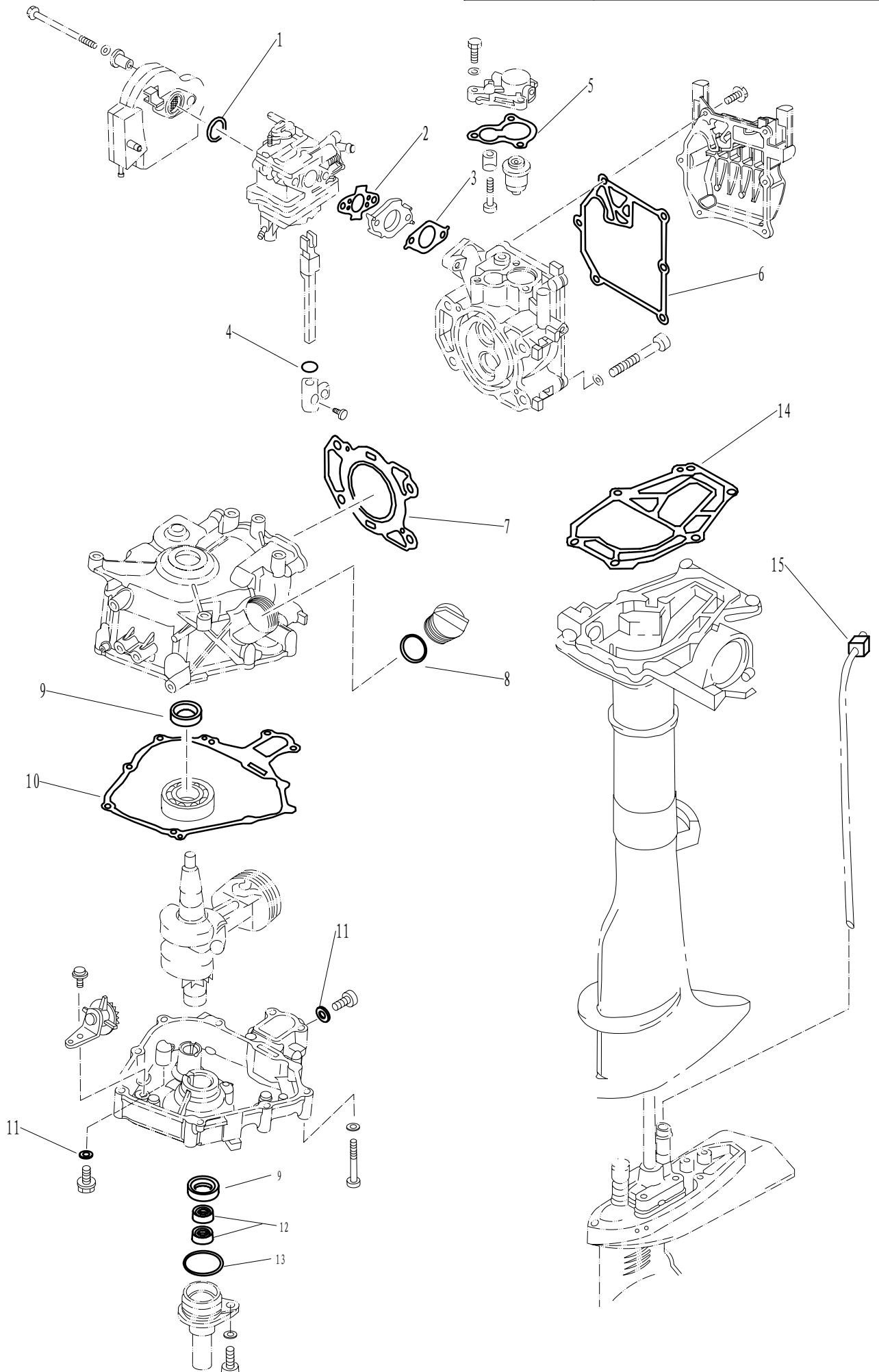

零部件名称:

修理套件2

PARTS NAME:

REPAIR KIT 2

