

1	15FMH-01001-P	63W-42610-20-4D	TOP COWLING 9.9 (SEA PRO)	капот в сборе	1
1	15FMH-01001-P	63W-42610-20-4D	TOP COWLING 15 (SEA PRO)	капот в сборе	1
2	15FMH-01002	63V-42615-00	SEAL		1
3	15FMH-01003	6G1-42651-02	HOOK		1
4	15FMH-01004-1	90266-04M04	RIVET		2
5	15FMH-01005	6L2-42647-00	HOLDER, CLAMP BAND		1
6	15FMH-01004-2	90266-04M04	RIVET		2
7	15FMH-01007-P	63V-42613-01-4D	MOLDING, AIR DUCT		1
8	15FMH-01008	97595-06516	BOLT, WITH WASHER		4
9	15FMH-01009-1	63V-W0070-11	Left stickers		1
9	15FMH-01009-2	63V-W0070-11	Right Label		1
10	15FMH-01010	63W-42677-20	Labels before		1
11	15FMH-01011	63W-42678-10	After labeling		1
12*	15FMH-01012		U-nails		14
13*	15FMH-01013		Cotton silencer		1
14*	15FMH-01014		Cotton silencer		2
9*			GRAPHIC SET 9.9(SEA PRO)		1
9*			GRAPHIC SET 15(SEA PRO)		1

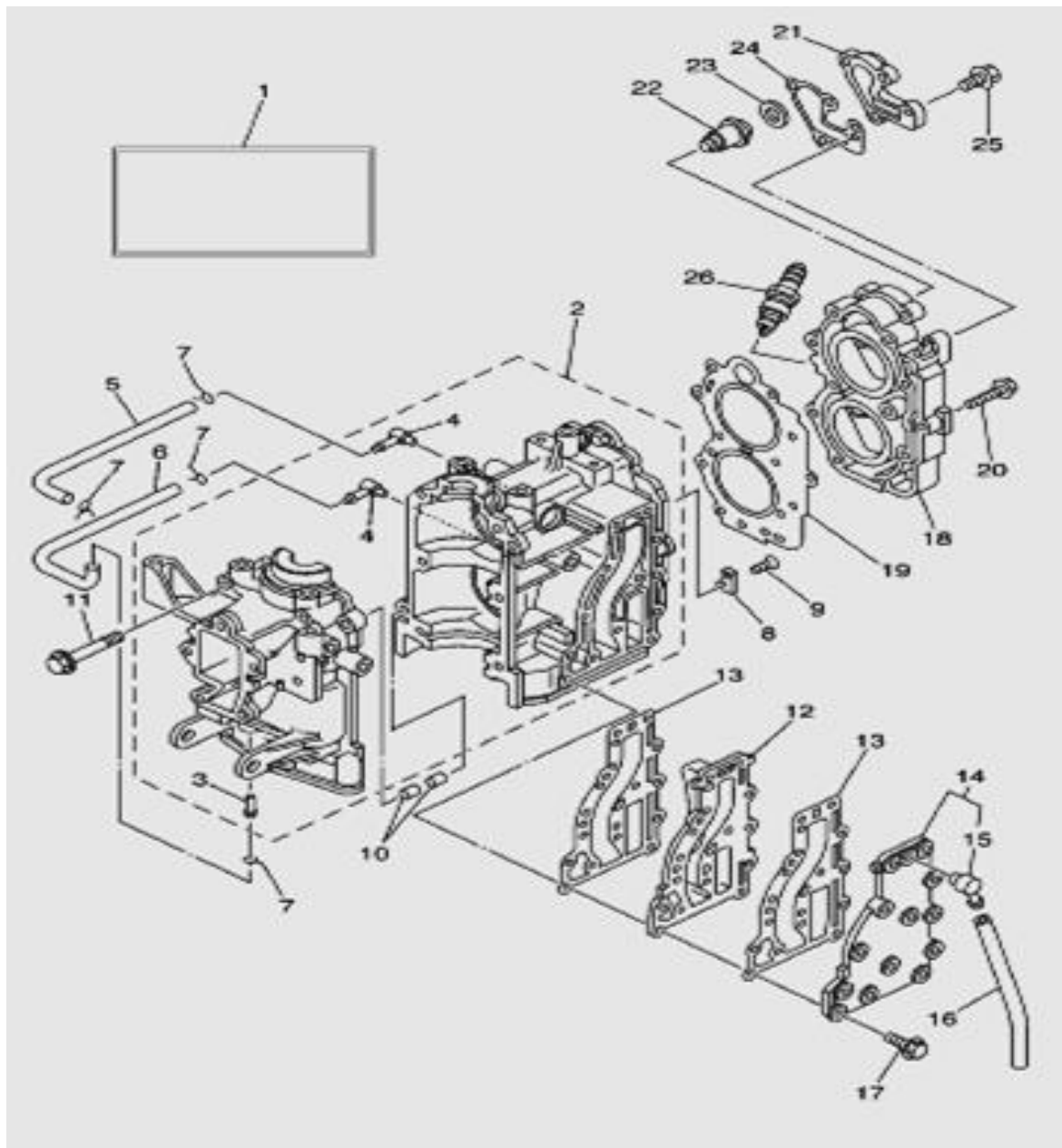

1	15FMH-02000	63V-W0090-03-1S	CRANK CYLINDER ASSY	двигатель в сборе	1
2	15FMH-02001	63V-15100-02-1S	CRANKCASE ASSY	блок цилиндров	1
2*	15FMH-02002		Cylinder		2
2*	15FMH-02003		Crankcase		1
3	15FMH-02004	624-14485-00	PIPE, JOINT		1
4	15FMH-02005	650-14485-03	PIPE, JOINT		2
5	15FMH-02006	90445-07M08	HOSE (L220)		1
6	15FMH-02007	90445-07M08	HOSE (L220)		1
7	15FMH-02008	90467-06016	CLIP		4
8	15FMH-02009	682-11325-00	ANODE		1
9	15FMH-02010	98780-05015	SCREW, FLAT HEAD		1
10	15FMH-02011	93606-12019	PIN, DOWEL		2
11	15FMH-02012	90119-08M07	BOLT, WITH WASHER		6
12	15FMH-02013	63V-41111-00-1S	INNER COVER, EXHAUST	крышка выпуска внутр.	1
13	15FMH-02014	63V-41112-A0	GASKET, EXHAUST INNER COVER	прокладка крышки выпуска	2
14	15FMH-02015	63V-41113-00-1S	OUTER COVER, EXHAUST	крышка выпуска внеш.	1
15	15FMH-02016	676-11372-00	NIPPLE, HOSE		1
16	15FMH-02017	90445-09104	HOSE (L300)		1
17	15FMH-02018	90119-06MA4	BOLT, WITH WASHER		13
18	15FMH-02019	6E7-11111-01-1S	HEAD, CYLINDER 1		1
19	15FMH-02020	63V-11181-A1	GASKET, CYLINDER HEAD 1		1

20	15FMH-02021	90105-07M05	BOLT, FLANGE		11
21	15FMH-02022	682-12413-00-1S	COVER, THERMOSTAT		1
22	15FMH-02023	6E5-12411-30	THERMOSTAT		1
23	15FMH-02023-1	90201-16M03	WASHER, PLATE		1
24	15FMH-02024	682-12414-A1	GASKET, COVER		1
25	15FMH-02025	90119-06MA2	BOLT, WITH WASHER		4
26	15FMH-02026	94702-00217	PLUG, SPARK (NGK B7HS-10)		2

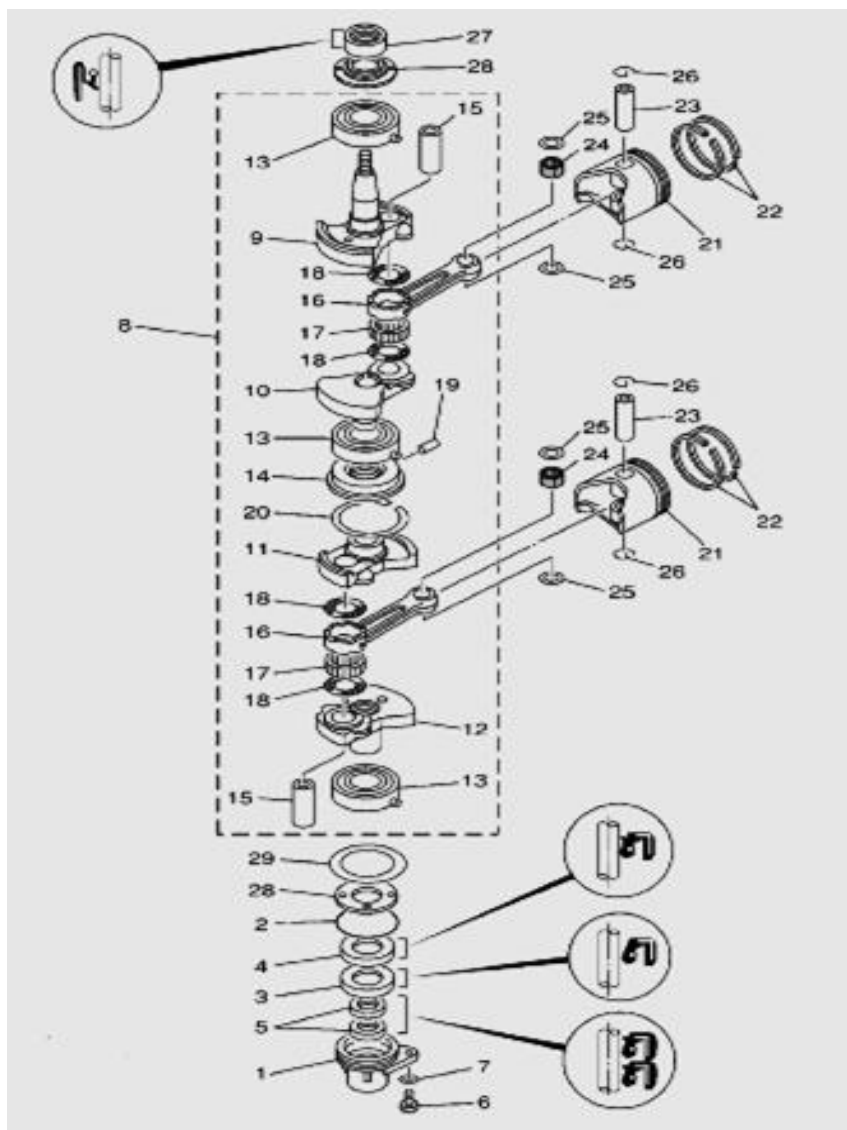

1	15FMH-03001	63V-15396-01-94	HOUSING, OIL SEAL		1
2	15FMH-03002	93210-46M16	O-RING		1
3	15FMH-03003	93101-25018	OIL SEAL		1
4	15FMH-03004	93102-25M48	OIL SEAL		1
5	15FMH-03005	93101-13018	OIL SEAL		2
6	15FMH-03006	97095-06016	BOLT		1
7		92995-06600	WASHER		1
8	15FMH-03007	63V-11400-01	CRANKSHAFT ASSY	коленвал в сборе	1
21	15FMH-03008	6E7-11631-00-97	PISTON (STD)	поршень	2
22	15FMH-03009	682-11610-01	PISTON RING SET (STD)	кольца поршневые	2
23	15FMH-03010	634-11633-00	PIN, PISTON	палец поршневой	2
24	15FMH-03011	93602-14104	PIN, DOWEL	игла подшипника	50
25	15FMH-03012	90201-14377	WASHER, PLATE		4
26	15FMH-03013	93450-15023	CIRCLIP		4
27	15FMH-03014	93110-23M00	OIL SEAL		1
28	15FMH-03015	63V-11445-00	SPACER		2

29	15FMH-03016	90201-46M29	WASHER, PLATE		1
----	-------------	-------------	---------------	--	---

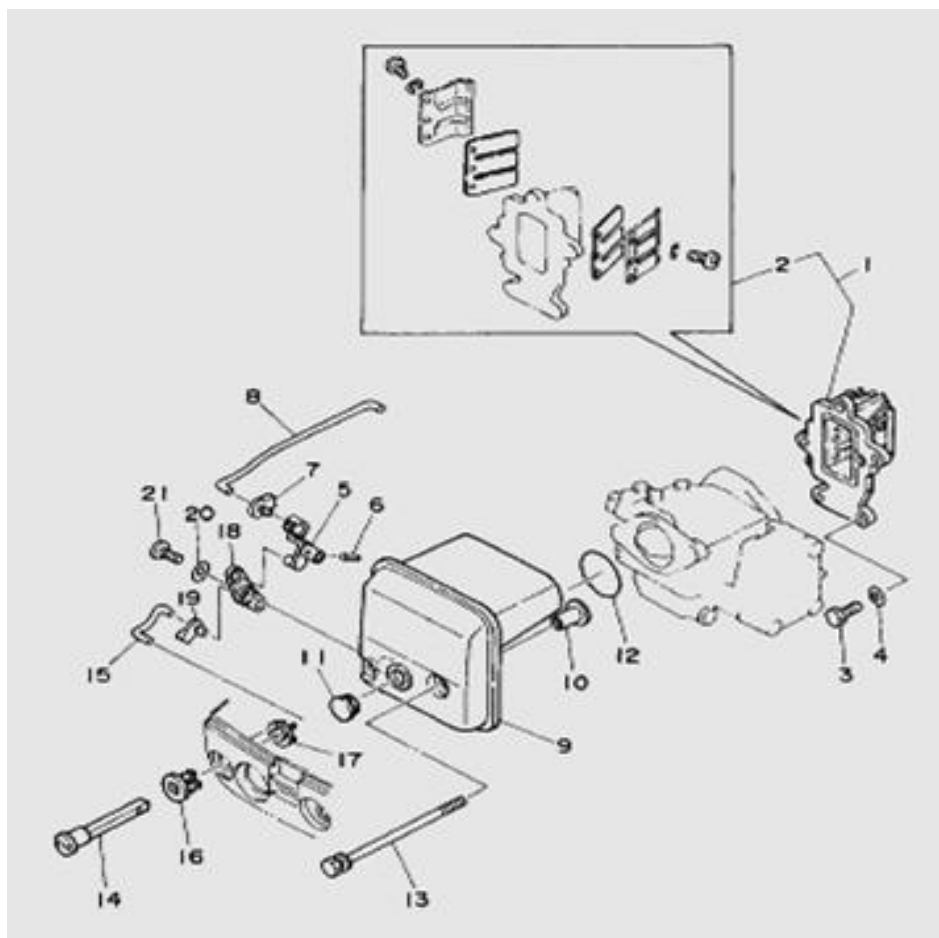

1	15FMH-04000	63W-13610-00	REED VALVE ASSY 15	клапанная площадка в сборе	1
3	15FMH-04002	97095-06020	BOLT		3
4		92995-06600	WASHER		3
8	15FMH-04006	63V-41257-00	ROD, CHOKE 2		1
9	15FMH-04007	63V-14440-00	SILENCER ASSY, INTAKE		1
10	15FMH-04008	90387-06M15	COLLAR		2
11	15FMH-04009	90480-12M25	GROMMET		1
12	15FMH-04010	93210-35M86	O-RING		1
13	15FMH-04011	90119-06M94	BOLT, WITH WASHER		2
14	15FMH-04012	6H4-41271-01	KNOB, CHOKE	ручка подсоса	1
15	15FMH-04013	63V-41256-00	ROD, CHOKE 1		1
16	15FMH-04014	689-41273-00	GROMMET		1
17	PNFM40E-04017	6J8-41274-00	GROMMET 2		1
18	15FMH-04016	63V-41252-00	LEVER, CHOKE 1		1
19	15FMH-04017	661-41262-02	JOINT, CHOKE LEVER		1
20	15FMH-04018	90201-05M09	WASHER, PLATE		1
21	15FMH-04019	90164-05M03	SCREW, TAPPING		1

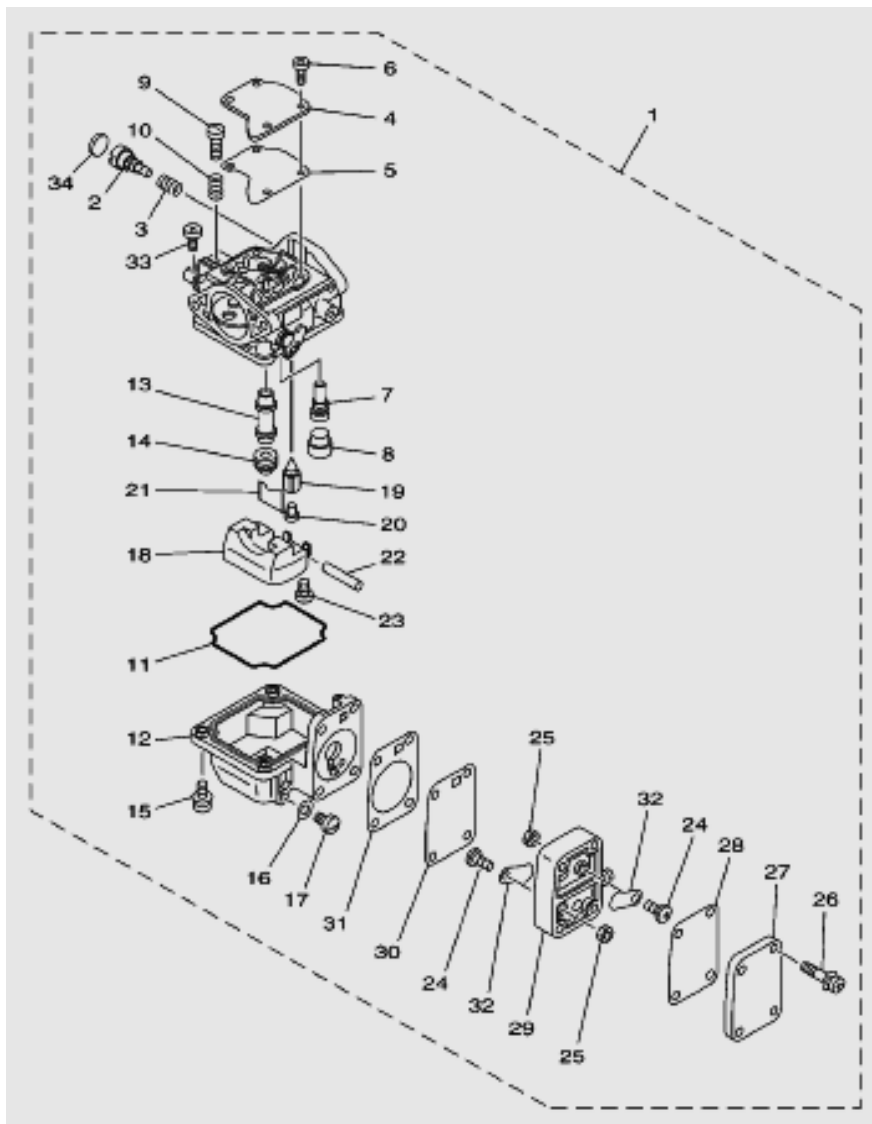

1	15FMH-05001	63V-14301-00	CARBURETOR ASSY 1	карбюратор в сборе	1
---	-------------	--------------	-------------------	--------------------	---

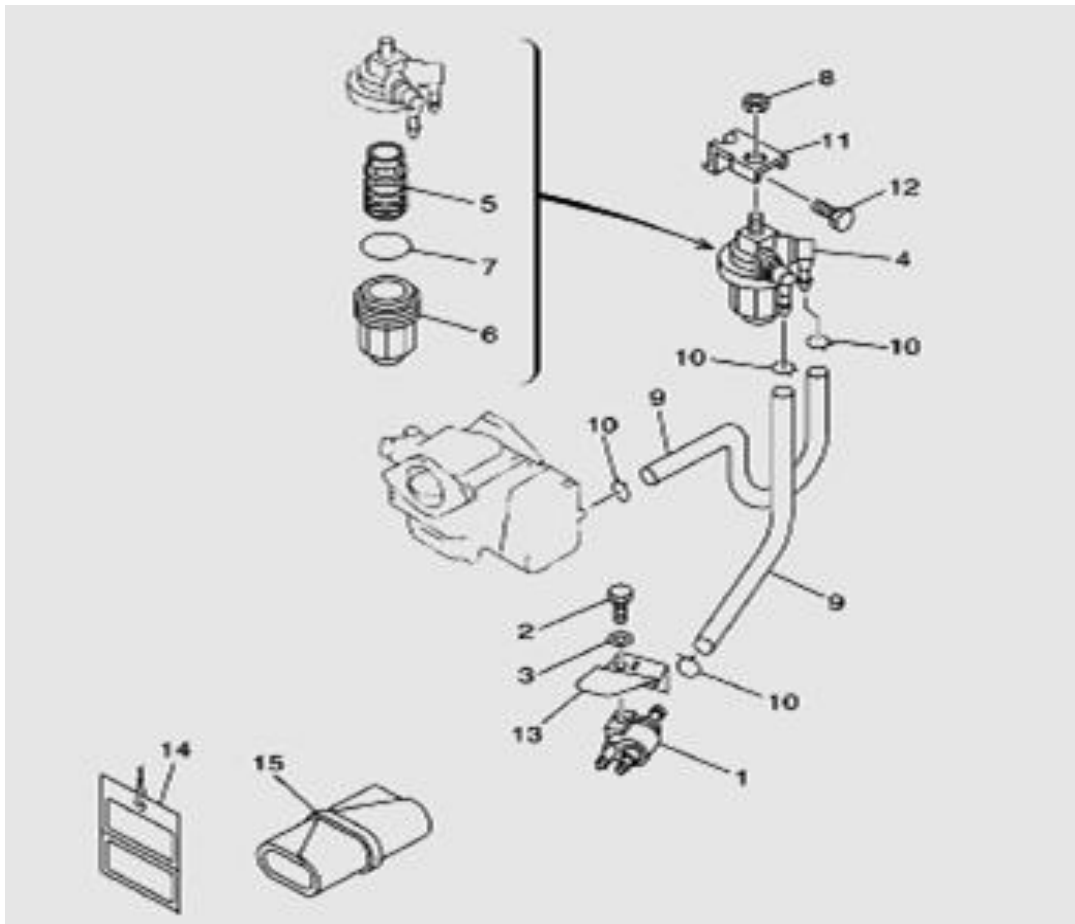

1	15FMH-06001	6G1-24304-02	FUEL PIPE JOINT COMP. 1	топливный коннектор	1
2	15FMH-06008	97095-06020	BOLT		1
3	15FMH-06008	92995-06600	WASHER		1
4	15FMH-06009	61N-24560-00	FILTER ASSY	топливный фильтр в сборе	1
5	15FMH-06010	61N-24563-00	ELEMENT, FILTER	фильтр. элемент	1
6	15FMH-06011	61N-24521-00	CUP, FILTER	корпус фильтра	1
7	15FMH-06012	93210-32738	O' RING		1
8	15FMH-06014	95380-08600	NUT		1
9	15FMH-06015	90445-09M00	HOSE (L180)		2
10	15FMH-06016	90467-08004	CLIP		4
11	15FMH-06017	682-24566-01	BRACKET, FILTER		1
12	15FMH-06018	97013-06010	BOLT		1
13	15FMH-06019	63V-24396-01	PLATE		1
14	15FMH-06020	61H-2819R-31	TAG, WARNING		1

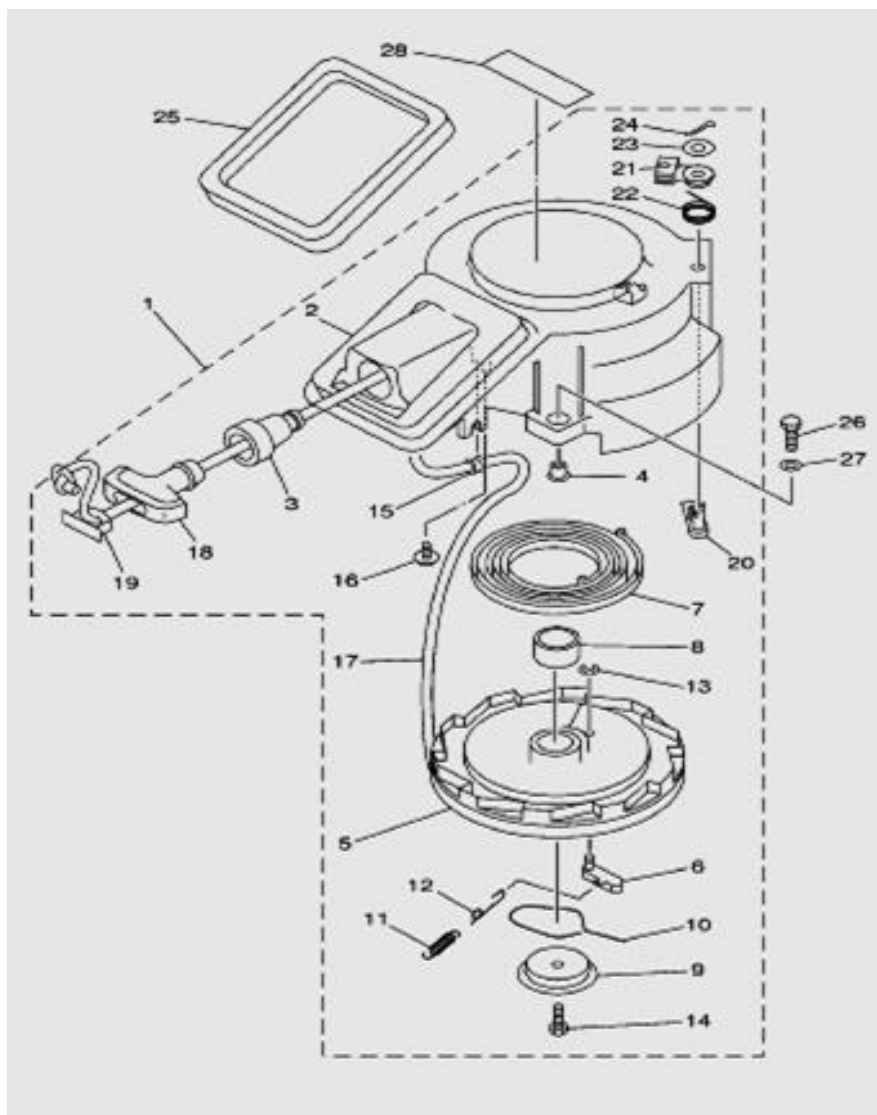

1	15FMH-07001	63V-15710-12	STARTER ASSY	руч. стартер в сборе	1
2	15FMH-07002	63V-15711-01	CASE, STARTER	корпус стартера	1
3	15FMH-07003	63V-15795-01	GUIDE, ROPE		1
4	15FMH-07004	90387-06M05	COLLAR		3
5	15FMH-07005	63V-15714-00	DRUM, SHEAVE	барабан стартера	1
6	15FMH-07006	63V-15741-00	PAWL, DRIVE	стопор-упор	1
7	15FMH-07007	63V-15713-00	SPRING, STARTER	пружина старт. большая	1
8	15FMH-07008	63V-15753-00	BUSH		1
9	15FMH-07009	63V-15716-00	PLATE, DRIVE		1
10	15FMH-07010	63V-15705-01	SPRING, DRIVE PAWL		1
11	15FMH-07011	63V-15767-01	SPRING		1
12	15FMH-07012	63V-15784-01	SPRING, RETURN		1
13	15FMH-07013	63V-15744-00	CIRCLIP		1
14	15FMH-07014	63V-15768-00	BOLT		1
15	15FMH-07015	63V-15764-00	COLLAR 1		1
16	15FMH-07016	63V-15793-00	SCREW		1
17	15FMH-07017		WIRE, STARTER (L:1800mm)		1
18	15FMH-07018	6G1-15755-00	HANDLE, STARTER		1
19	15FMH-07019	6G1-15779-00	COVER		1
20	15FMH-07020	63V-15794-00	STOPPER		1
21	15FMH-07021	63V-15748-00	PLUNGER, STARTER STOP		1
22	15FMH-07022	63V-15734-00	SPRING, RETURN		1
23	15FMH-07023	63V-15726-00	WASHER, FLAT		1
24	15FMH-07024	91490-16018	PIN, COTTER		1
25	15FMH-07025	63V-15762-00	SEAL, RUBBER 2		1

26	15FMH-07026	97095-06020	BOLT		3
27	15FMH-07027	92995-06600	WASHER		3
28	15FMH-07028	6A1-83625-41	MARK		1

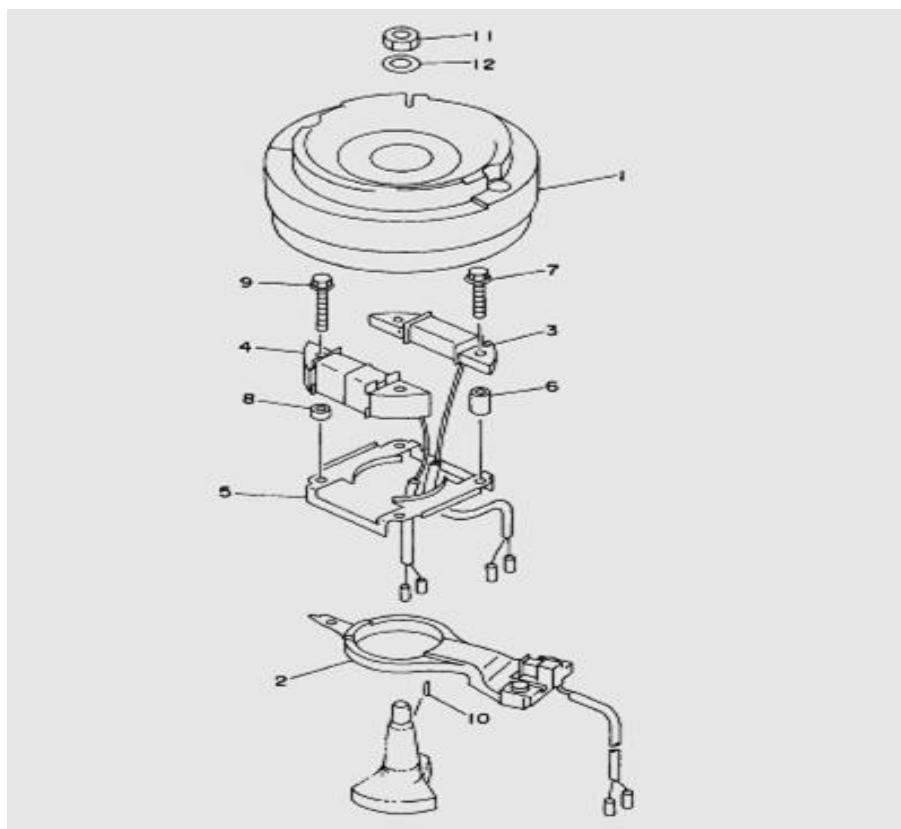

1	15FMH-08001	63V-85550-11	ROTOR ASSY	ротор (маховик) в сборе	1
2	15FMH-08002	63V-85580-01	COIL, PULSER	катушка импульсная	1
3	15FMH-08003	63V-85520-01	COIL, CHARGE	катушка генератора	1
4	15FMH-08004	63V-85533-00	COIL, LIGHTING	катушка световая	1
5	15FMH-08005	63V-41611-00	RETAINER, MAGNETO BASE		1
6	15FMH-08006	90387-06M53	COLLAR		2
7	15FMH-08007	90105-06M68	BOLT, FLANGE		2
8	15FMH-08008	90387-06M24	COLLAR		2
9	15FMH-08009	90105-06M69	BOLT, FLANGE		2
10	15FMH-08010	90280-05013	KEY, WOODRUFF		1
11	15FMH-08011	90170-12066	NUT		1
12	15FMH-08012	90201-12472	WASHER, PLATE		1

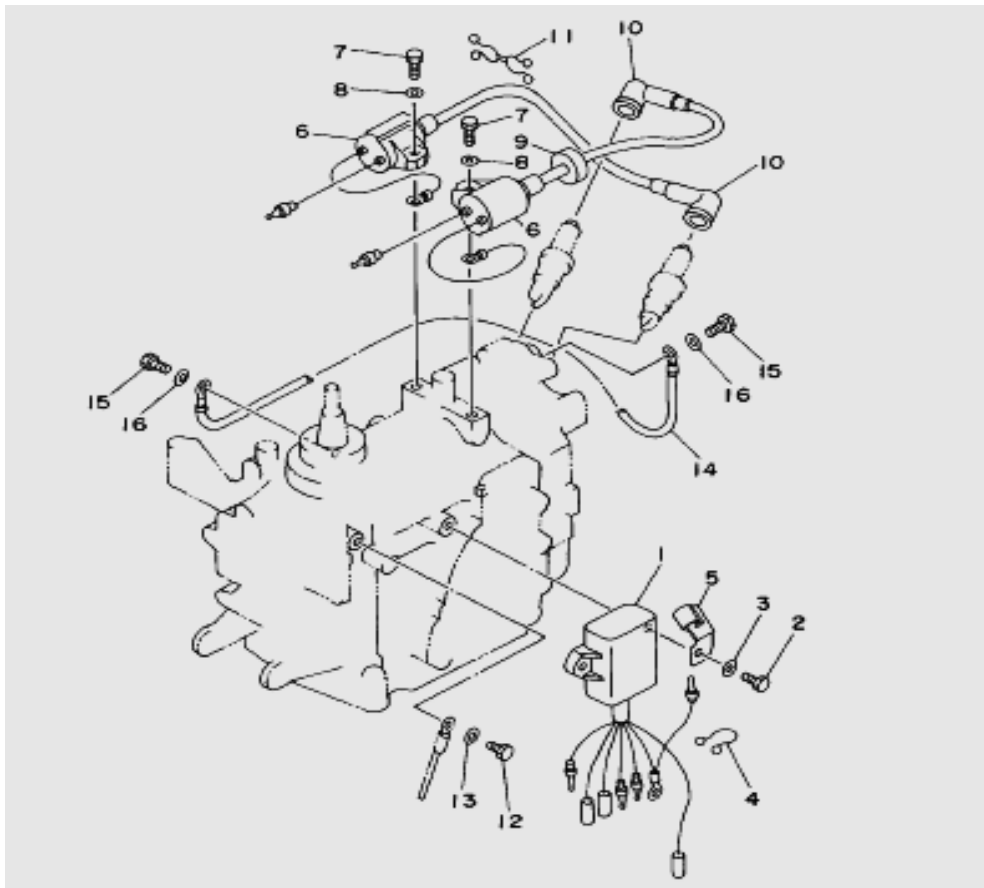

1	15FMH-09001	63V-85540-01	C.D.I. UNIT ASSY	1
2	15FMH-09002	97095-06020	BOLT	2
3		92995-06600	WASHER	2
4	15FMH-09003	90464-15M11	CLAMP	1
5	15FMH-09004	90465-08M61	CLAMP	1
6	15FMH-09005	63V-85570-00	IGNITION COIL ASSY	2
7	15FMH-09006	97095-06018	BOLT	2
8		92995-06600	WASHER	2
9	15FMH-09007	90480-25161	GROMMET	1
10	15FMH-09008	663-82370-01	PLUG CAP ASSY	2
11	15FMH-09009	90464-08M02	CLAMP	1
12	15FMH-09010	97095-06012	BOLT	1
13		92995-06600	WASHER	1
14	15FMH-09011	662-82519-00	WIRE, EARTH LEAD	1
15	15FMH-09015	97095-06012	BOLT	2
16		92995-06600	WASHER	2
19	15FMH-09018		RECTIFIER ASSY	1

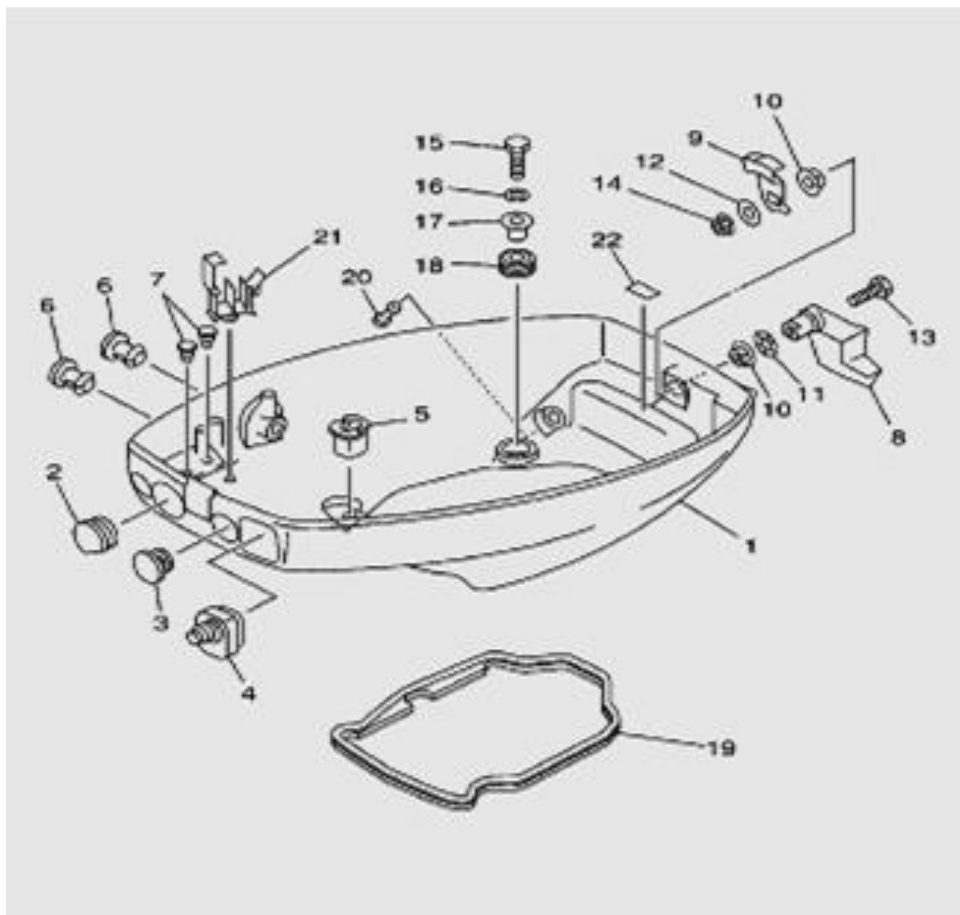

1	15FMH-10001	63V-42711-03-4D	COWLING, BOTTOM	поддон двигателя	1
2	15FMH-10002	682-42724-00	GROMMET		1
3	15FMH-10003	682-42725-02	GROMMET		1
4	15FMH-10004	63V-42726-00	GROMMET		1
5	15FMH-10005	682-42727-00	GROMMET		1
6	15FMH-10006	6G1-42748-00	GROMMET		2
7	15FMH-10007	90480-06M19	GROMMET		2
8	15FMH-10008	63V-42815-01-4D	LEVER, CLAMP	ручка колпака	1
9	15FMH-10009	6E7-42816-00	LEVER, CLAMP	защелка ручки	1
10	15FMH-10010	90386-12M45	BUSH	втулка	2
11	15FMH-10011	90206-12052	WASHER, WAVE		1
12	15FMH-10012	90201-06068	WASHER, PLATE		1
13	15FMH-10013	97095-06025	BOLT		1
14	15FMH-10014	95380-06700	NUT		1
15	15FMH-10015	97095-06025	BOLT		4
16	15FMH-10016	92995-06600	WASHER		4
17	15FMH-10017	90387-06034	COLLAR		4
18	15FMH-10018	90480-15M31	GROMMET		4
19	15FMH-10019	63V-42716-02	RUBBER, SEAL 1		1
20	15FMH-10020	6H3-44391-01	NIPPLE, HOSE		1
21	15FMH-10021	90465-25M57	CLAMP		1
22	15FMH-10022	6E7-42791-00	MARK		1

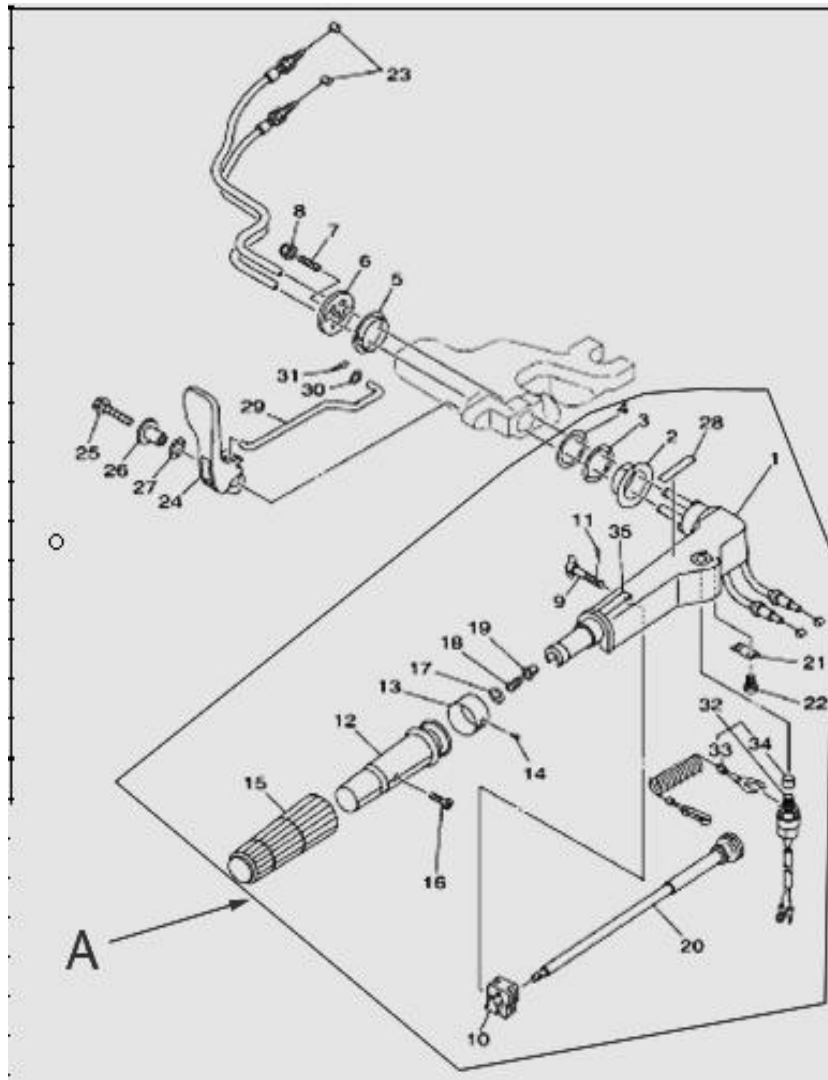

A	15FMH11001A		HANDLE, STEERING-A	румпель в сборе	1
1	15FMH-11001	63V-42111-01-4D	HANDLE, STEERING	корпус румпеля	1
2	15FMH-11002	90386-34M97	BUSH	втулка	1
3	15FMH-11003	90206-36M21	WASHER, WAVE	шайба	1
4	15FMH-11004	90202-36M55	WASHER, PLATE	шайба	1
5	15FMH-11005	90386-33M96	BUSH	втулка	1
6	15FMH-11006	6G1-42131-02	COVER, HANDLE STEERING	шайба	1
7	15FMH-11007	90116-08016	BOLT, STUD		1
8	15FMH-11008	90185-08057	NUT, SELF-LOCKING		1
9	15FMH-11009	6G1-42125-01	BOLT, FRICTION ADJUSTING		1
10	15FMH-11011	6G1-42126-00	FRICTION, STEERING HANDLE GRIP		1
11	15FMH-11012	91490-16010	PIN, COTTER		1
12	15FMH-11013	664-42119-00	GRIP, STEERING HANDLE		1
13	15FMH-11014	6H2-42137-00	INDICATOR, THROTTLE		1
14	15FMH-11015	90269-02M09	RIVET		1
15	15FMH-11016	6G1-42177-00	RUBBER, HANDLE		1
16	15FMH-11017	90149-05M13	SCREW		1
17	15FMH-11018	92903-10600	WASHER, PLATE		1
18	15FMH-11019	90501-23215	SPRING, COMPRESSION		1
19	15FMH-11020	90386-08032	BUSH		1
20	15FMH-11021	6G1-42138-01	LEVER, THROTTLE		1
21	15FMH-11023	6E0-42159-02	STAY		1
22	15FMH-11024	97885-05012	SCREW, PAN HEAD		2
23	15FMH-11025	6L2-26301-00	THROTTLE CABLE ASSY		2
24	15FMH-11026	63V-44111-02	HANDLE, GEAR SHIFT		1

25	15FMH-11027	90119-06M05	BOLT, WITH WASHER		1
26	15FMH-11028	90387-06M86	COLLAR		1
27	15FMH-11029	90206-15M18	WASHER, WAVE		1
28	15FMH-11030	6E0-44191-11	INDICATOR, SHIFT		1
29	15FMH-11031	63V-44124-02	LINK, SHIFT ROD		1
30	15FMH-11032	90202-06009	WASHER, PLATE		1
31	15FMH-11033	90468-18008	CLIP		1
32	15FMH-11034	65W-82575-01	ENGINE STOP SWITCH ASSY	кнопка останова двигателя	1
33	15FMH-11035	682-82556-00	STOPPER	трос страховочный	1
34	15FMH-11036	689-8257Y-00	CAP		1
35	15FMH-11037	6E0-83627-41	LABEL, CAUTION 7		1

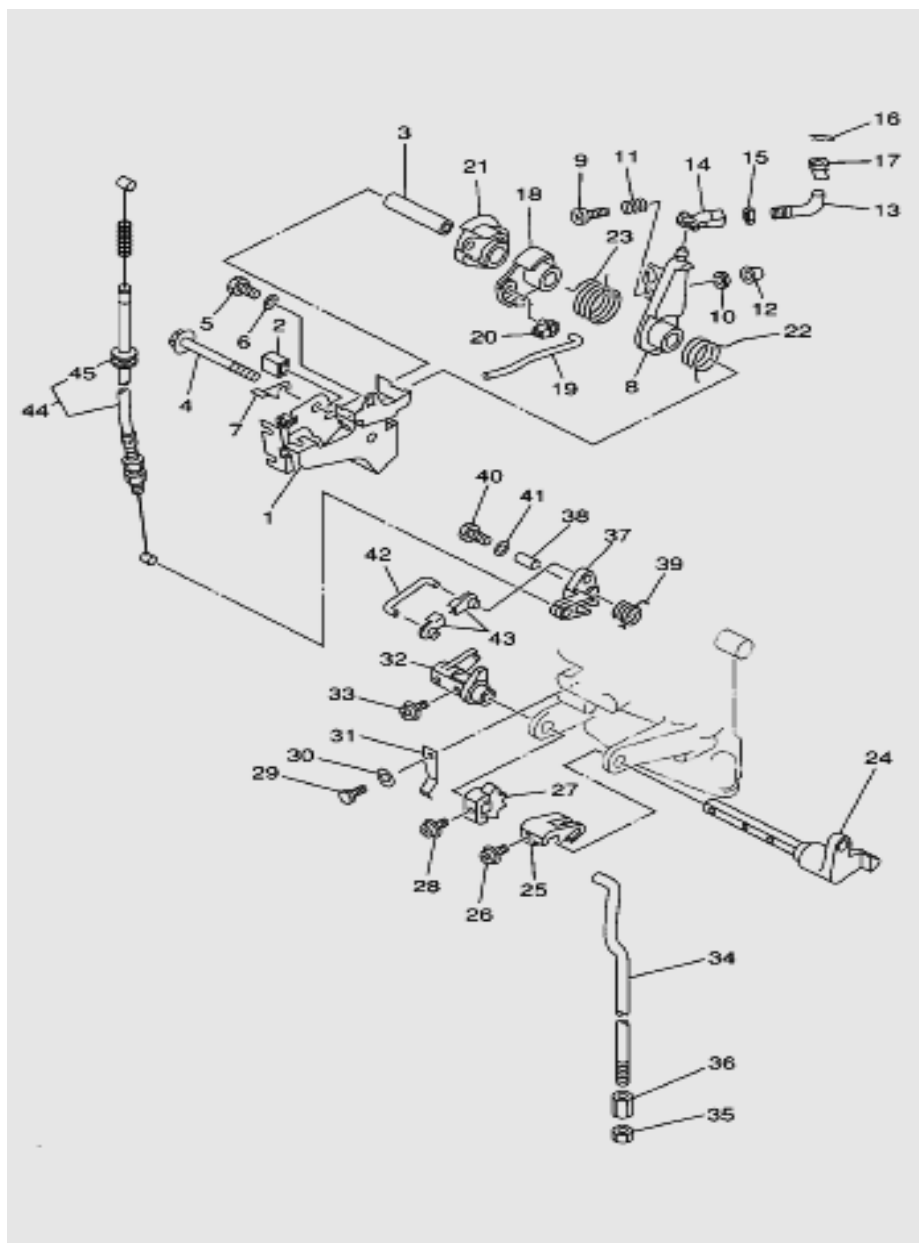

1	15FMH-12001	63V-14497-02	STAY, THROTTLE WIRE		1
2	15FMH-12043	689-44194-00	CAP		1
3	15FMH-12002	90387-06M50	COLLAR		1
4	15FMH-12003	95895-06065	BOLT, FLANGE		1
5	15FMH-12004	97095-06012	BOLT		1
6		92995-06012	WASHER		1
8	15FMH-12005	63V-41631-00	LEVER, MAGNETO CONTROL	рычаг управления заслонкой	1
9	15FMH-12006	97885-06030	SCREW, PAN HEAD		1
10	15FMH-12007	95380-06600	NUT, HEXAGON		1

11	15FMH-12008	90501-12M16	SPRING, COMPRESSION		1
12	15FMH-12009	688-44194-00	CAP		1
13	15FMH-12010	63V-41238-00	JOINT, LINK		1
14	15FMH-12011	6H4-41237-00	JOINT, LINK		1
15	15FMH-12012	95380-05700	NUT		1
16	15FMH-12013	90468-10005	CLIP		1
17	15FMH-12014	63V-41223-00	WASHER, LOCK 1		1
18	15FMH-12015	63V-41283-01	LEVER, FREE ACCEL.	ролик привода дросселя	1
19	15FMH-12016	63V-41211-00	LINK, ACCEL.		1
20	15FMH-12017	661-41262-02	JOINT, CHOKE LEVER		1
21	15FMH-12018	63V-41638-00	PULLEY		1
22	15FMH-12019	90508-16M37	SPRING, TORSION		1
23	15FMH-12020	90508-20M38	SPRING, TORSION		1
24	15FMH-12021	63V-44123-01	ARM, SHIFT ROD		1
25	15FMH-12023	63V-44121-01	LEVER, SHIFT ROD	фиксатор тяги п/п	1
26	15FMH-12024	90159-05M25	SCREW, WITH WASHER		1
27	15FMH-12025	63V-44125-00	LEVER, SHIFT ROD		1
28	15FMH-12027	90159-05M25	SCREW, WITH WASHER		1
29	15FMH-12028	97095-06012	BOLT		1
30		92995-06600	WASHER		1
31	15FMH-12029	63V-44116-00	SPRING		1
32	15FMH-12030	63V-44122-01	BUSHING, SHIFT ROD LEVER		1
33	15FMH-12031	90159-05M25	SCREW, WITH WASHER		1
34	15FMH-12032	63V-44143-01	ROD, SHIFT		1
35	15FMH-12033	95380-06700	NUT		1
36	15FMH-12034	90170-06015	NUT		1
37	15FMH-12035	63V-15746-10	ARM		1
38	15FMH-12036	90387-06M06	COLLAR		1
39	15FMH-12037	90508-08M39	SPRING, TORSION		1
40	15FMH-12038	97095-06020	BOLT		1
41		92995-06600	WASHER		
42	15FMH-12039	6L2-15747-00	LINK		1
43	15FMH-12040	661-41262-02	JOINT, CHOKE LEVER		2
44	15FMH-12041	63V-15770-01	CABLE COMP., STARTER STOP	трос тормозной системы	1
45	15FMH-12042	90480-10M16	GROMMET		1

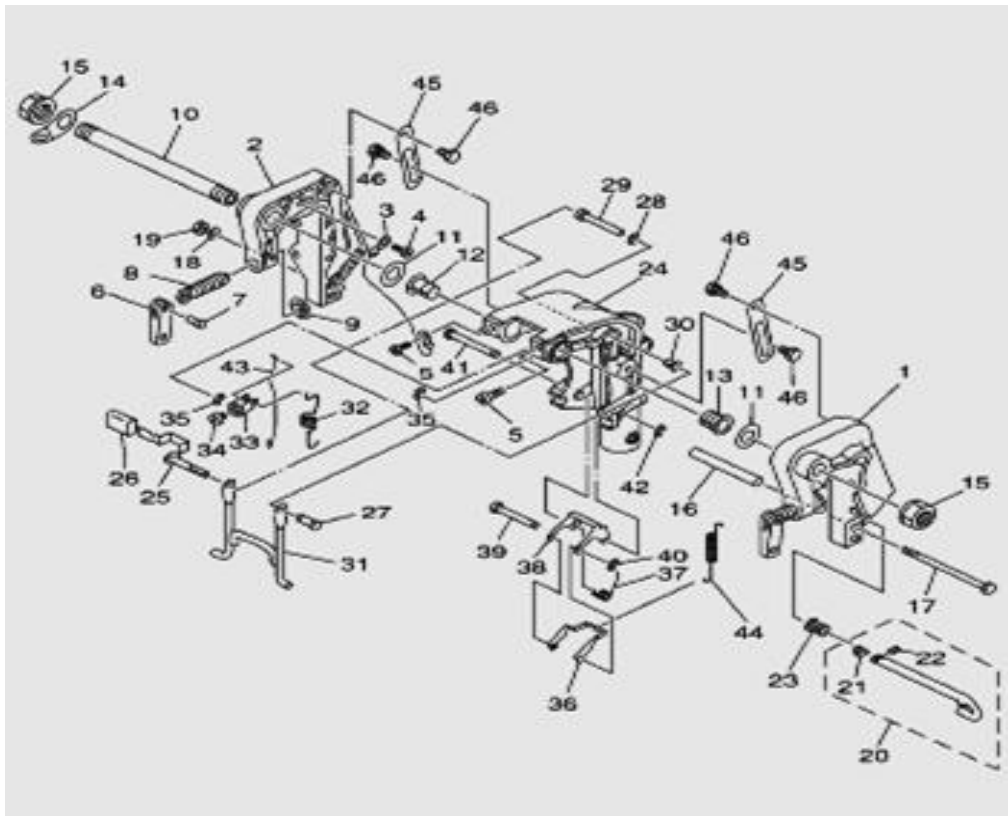

1	15FMH-13001	63V-43111-06-4D	BRACKET, CLAMP	опора зажимная левая	1
2	15FMH-13002	63V-43112-07-4D	BRACKET, CLAMP	опора зажимная правая	1
3	15FMH-13003	66M-82148-00	WIRE, LEAD 4		1
4	15FMH-13007	97885-06008	SCREW, PAN HEAD		1
5	15FMH-13008	97885-08010	SCREW, PAN HEAD		2
6	15FMH-13009	6E0-43118-01	HANDLE, TRANSOM CLAMP		2
7	15FMH-13010	90243-04M01	PIN		2
8	15FMH-13011	6E7-43116-00	SCREW, TRANSOM CLAMP		2
	15FMH-13011-1		BOLT		
9	15FMH-13012	648-43114-01	PAD, TRANSOM CLAMP		2
10	15FMH-13013	63W-43131-01	BOLT, CLAMP BRACKET		1
11	15FMH-13014	90202-22M54	WASHER, PLATE		2
12	15FMH-13015	90386-22M94	BUSH		1
13	15FMH-13015	90386-22M94	BUSH		1
14	15FMH-13017	6J8-43113-01	PLATE, CLAMP BRACKET		1
15	15FMH-13018	90185-22043	NUT, SELF-LOCKING		2
16	15FMH-13021	90387-06M13	COLLAR		1
17	15FMH-13022	90101-06M29	BOLT		1
18	15FMH-13023	92995-06600	WASHER		1
19	15FMH-13024	95380-06700	NUT		1
20	15FMH-13025	689-43160-00	TILT ROD ASSY		1
21	15FMH-13026	689-43165-00	PLATE, TILT LOCK		1
22	15FMH-13028	91690-30008	PIN, SPRING		1
23	15FMH-13029	90502-10M07	SPRING, CONICAL		1
24	15FMH-13030	63V-43311-03-4D	BRACKET, SWIVEL 1	крепление поворотное	1
25	15FMH-13031	66M-43630-01	TILT LEVER ASSY	рычаг поворотный в сборе	1
26	15FMH-13034	682-43318-01	COVER		1
27	15FMH-13035	63V-43191-00	SHAFT, STOPPER		1
28	15FMH-13036	90202-07M60	WASHER, PLATE		1
29	15FMH-13037	90387-07M07	COLLAR		1
30	15FMH-13038	90386-07M95	BUSH		1
31	15FMH-13039	66M-43350-01	RECEIVER ASSY	стойка опорная	1
32	15FMH-13043	90507-20M00	SPRING, TENSION		1
33	15FMH-13044	63V-43641-01	LEVER, TILT		1

34	15FMH-13045	90157-05014	SCREW, PAN HEAD		1
35	15FMH-13046	99080-05600	CIRCLIP		2
36	15FMH-13047	63V-43614-10	PLATE, TILT LOCK		1
37	15FMH-13048	90508-18M41	SPRING, TORSION		1
38	15FMH-13049	66R-43615-00	PLATE, TILT LOCK		1
39	15FMH-13050	66R-43611-00	SHAFT, TILT LOCK		1
40	15FMH-13051	93430-04M03	CIRCLIP		1
41	15FMH-13052	63V-43659-00	SHAFT, REVERSE LOCK		1
42	15FMH-13053	99080-05600	CIRCLIP		1
43	15FMH-13054	66R-43617-00	ROD, TILT LOCK		1
44	15FMH-13055	63V-43656-00	SPRING, REVERSE LOCK 1		1
45	15FMH-13056	63V-43181-00	LEVER, TILT STOP	планка стопор	2
46	15FMH-13057	90109-06M84	BOLT		4
47	15FMH-13058				1

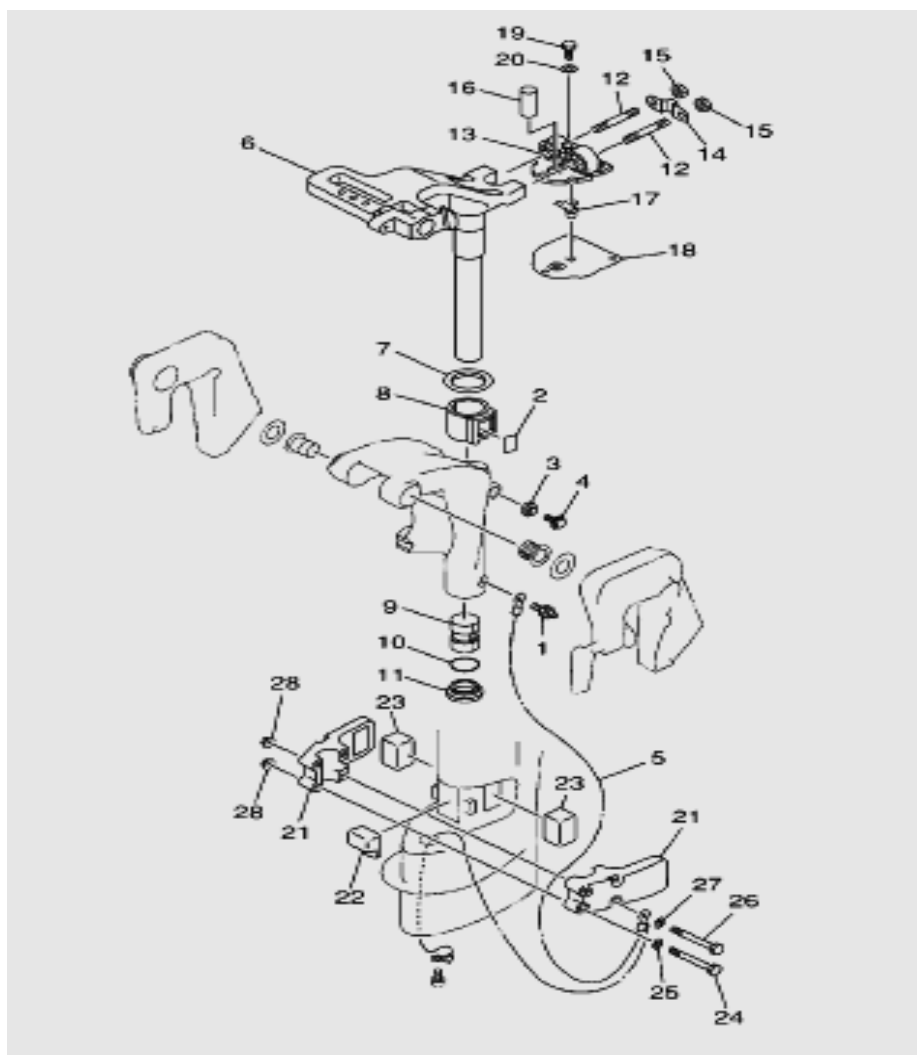

1	15FMH-14001	93700-06M03	NIPPLE, GREASE		1
2	15FMH-14002	63V-42528-00	PLATE, FRICTION		1
3	15FMH-14003	689-43373-01	SEAL, DAMPER		1
4	15FMH-14004	90105-06M07	BOLT, FLANGE		1
5	15FMH-14005	63V-82127-00	WIRE, LEAD 2		1
6	15FMH-14006	63V-42511-04-4D	BRACKET, STEERING	крепление рычаг	1
7	15FMH-14012	90209-40008	WASHER		1
8	15FMH-14009	65F-42537-00	BUSHING, PIVOT SHAFT		1
9	15FMH-14010	90386-30048	BUSH		1
10	15FMH-14011	93210-29M94	O-RING		1
11	15FMH-14008	90386-30M60	BUSH		1

12	15FMH-14013	90116-08M54	BOLT, STUD		2
13	15FMH-14014	63V-44514-01-5B	MOUNT DAMPER, UPPER SIDE		1
14	15FMH-14017	63V-44526-00	PLATE		1
15	15FMH-14018	95380-08600	NUT		2
16	15FMH-14019	90387-16002	COLLAR		1
17	15FMH-14020	63V-44366-01	DAMPER, WATER SEAL		1
18	15FMH-14021	63V-45114-A1	GASKET, UPPER CASING		1
19	15FMH-14022	97095-06018	BOLT		3
20		92995-06600	WASHER		
21	15FMH-14023	83V-44551-01-4D	HOUSING, LOWER MOUNT RUBBER	корпус амортизатора	2
22	15FMH-14024	63V-44557-00	MOUNT DAMPER, LOWER FRONT		1
23	15FMH-14025	682-44555-00	MOUNT DAMPER, LOWER SIDE		2
24	15FMH-14026	97075-06055	BOLT		2
25		92995-06600	WASHER		2
26	15FMH-14027	97075-06075	BOLT		2
27		92995-06600	WASHER		
28	15FMH-14028	90179-06M28	NUT		4

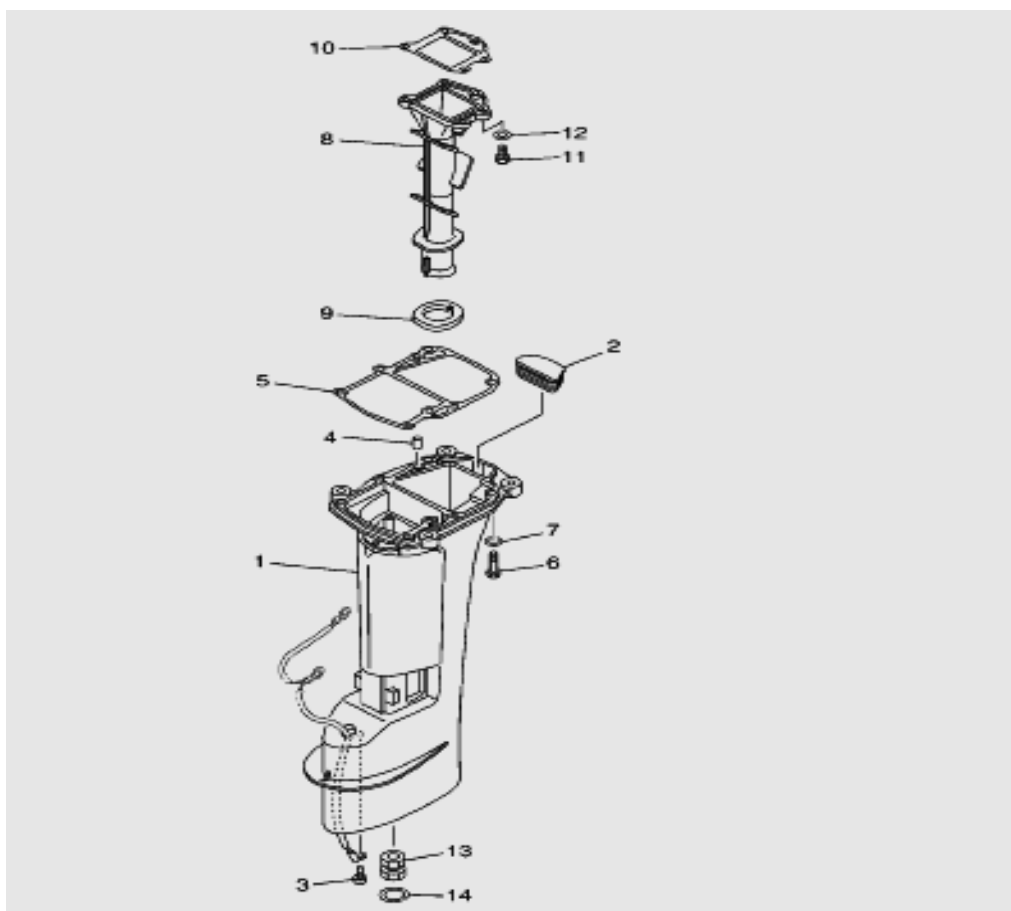

1	15FMH-15001S	63V-45111-05-4D	CASING, UPPER (S)	дейдвуд	1
2	15FMH-15002	63V-45126-01	PLATE, SEAL DAMPER		1
3	15FMH-15003	90157-06M06	SCREW, PAN HEAD		1
4	15FMH-15004	93606-12019	PIN, DOWEL		2
5	15FMH-15005	63V-45113-A1	GASKET, UPPER CASING		1
6	15FMH-15006	97095-08030	BOLT		6
7		92995-08600	WASHER		6
8	15FMH-15007	65F-41131-00-5B	MANIFOLD, EXT. 1	труба, выпускной коллектор	1
9	15FMH-15008	63V-41135-00	GASKET, EXHAUST MANIFOLD		1
10	15FMH-15009	63V-41133-A1	GASKET, EXHAUST MANIFOLD 1		1
11	15FMH-15010	97095-06020	BOLT		5
12		92995-06600	WASHER		5

13	15FMH-15011	682-45318-00	BUSHING, DRIVE SHAFT	втулка торсинного вала	1
14	15FMH-15013	93420-30042	CIRCLIP		1

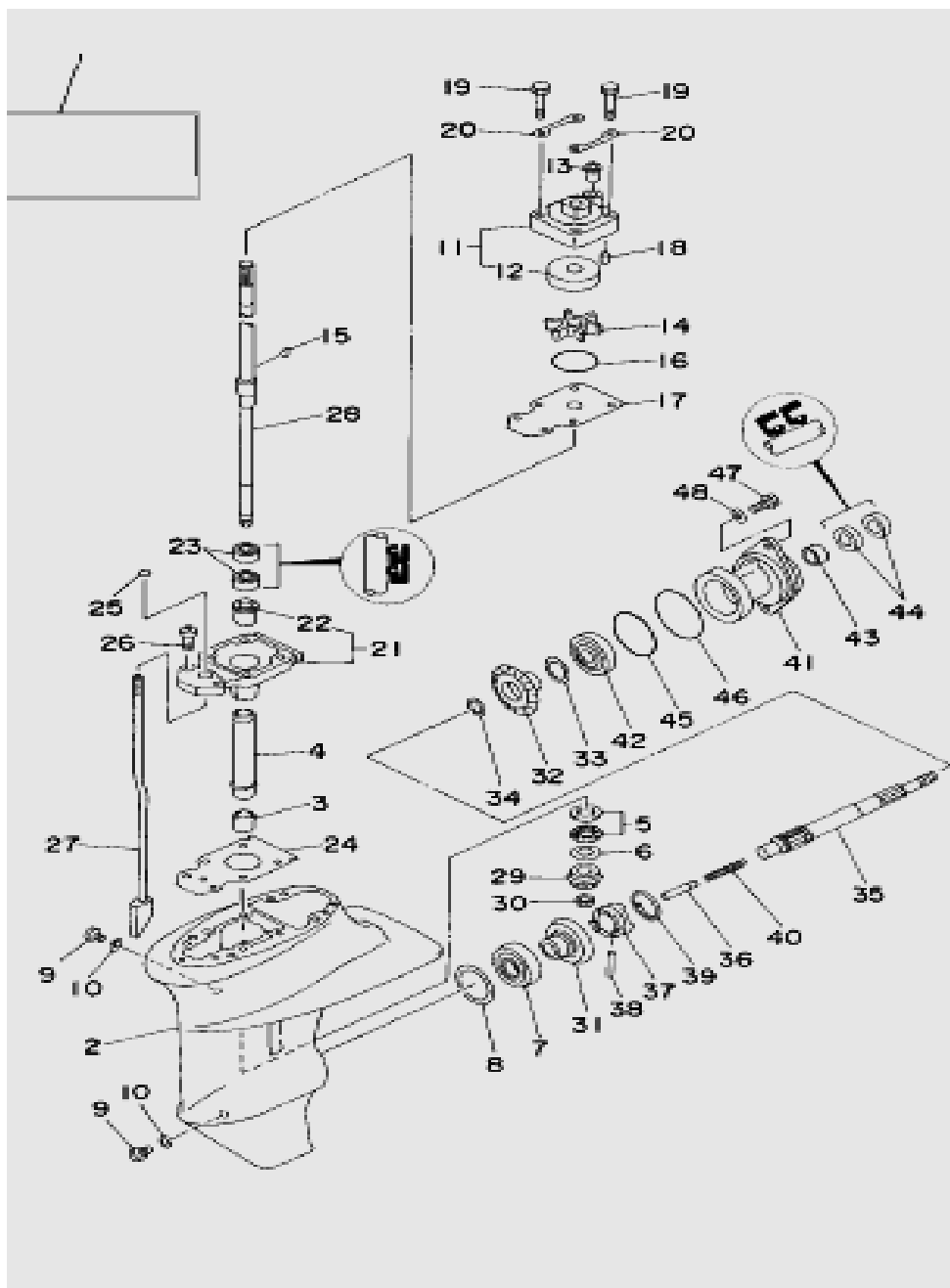

1	15FMH-16001S	63V-45300-03-4D	LOWER UNIT ASSY (S)	редуктор в сборе	1
2	15FMH-16002	63V-45311-01-4D	CASING, LOWER		1
3	15FMH-16003	93315-314V8	BEARING		1
4	15FMH-16004	63V-45536-00	SLEEVE, DRIVE SHAFT	втулка	1
5	15FMH-16005	93341-41414	BEARING		1
6	15FMH-16006		SHIM	шайба регулировочная	1
6		6E8-45587-10-13	SHIM (T: 1.13mm)	шайба регулировочная	1
6		6E8-45587-10-20	SHIM (T: 1.20mm)	шайба регулировочная	1
7	15FMH-16007	93332-00005	BEARING		1
8	15FMH-16054		SHIM (T: 0.05mm)	шайба регулировочная	1
8		664-45567-01-10	SHIM (T: 0.10mm)	шайба регулировочная	1
8		664-45567-01-12	SHIM (T: 0.2mm)	шайба регулировочная	1
8		664-45567-01-15	SHIM (T: 0.15mm)	шайба регулировочная	1
8		664-45567-01-18	SHIM (T: 0.18mm)	шайба регулировочная	1
8		664-45567-01-30	SHIM (T: 0.30mm)	шайба регулировочная	1
8		664-45567-01-40	SHIM (T: 0.40mm)	шайба регулировочная	1

8		664-45567-01-50	SHIM (T: 0.50mm)	шайба регулировочная	1
9	15FMH-16008	90340-08002	PLUG, STRAIGHT SCREW	заглушка масляного отверстия	2
10	15FMH-16009	90430-08020	GASKET		2
11	15FMH-16010	63V-44301-00	WATER PUMP HOUSING COMP STD	корпус помпы	1
11	15FMH-16010W	63V-44301-40	WATER PUMP HOUSING COMP CHR		1
12	15FMH-16011	63V-44322-00	INSERT, CARTRIDGE STD	стакан помпы	1
12	15FMH-16011W	63V-44322-40	INSERT, CARTRIDGE CHR		1
13	15FMH-16012	647-44366-00	DAMPER, WATER SEAL		1
14	15FMH-16013	63V-44352-01	IMPELLER (OTH15,F15)		1
15	15FMH-16015	63V-44338-00	KEY, WOODRUFF		1
16	15FMH-16016	93210-44398	O-RING		1
17	15FMH-16017	63V-44323-00	OUTER PLATE, CARTRIDGE STD	пластина помпы	1
17	15FMH-16017W	63V-44323-40	OUTER PLATE, CARTRIDGE CHR		1
18	15FMH-16018	93604-12M07	PIN, DOWEL		2
19	15FMH-16019	97080-08045	BOLT		4
20	15FMH-16020	63V-44328-00	PLATE		2
21	15FMH-16021	63V-45331-00-5B	HOUSING, BEARING	обойма подшипника	1
22	15FMH-16022	90381-14020	BUSH, SOLID		1
23	15FMH-16023	93101-20048	OIL SEAL 20*30*6		2
24	15FMH-16024	63V-45315-A0	PACKING, LOWER CASING		1
25	15FMH-16025	93210-06ME6	O-RING		1
26	15FMH-16026	97080-08025	BOLT		2
27	15FMH-16027S	63V-44150-00	SHIFT CAM ASSY (S)		1
27	15FMH-16027	63V-44150-10	SHIFT CAM ASSY (L)		1
28	15FMH-16031S	63V-45510-01	DRIVE SHAFT ASSY	вертикальный вал S	1
28	15FMH-16031	63V-45510-11	DRIVE SHAFT ASSY		1
29	15FMH-16034	63V-45551-00	PINION (13T)	шестерня ведущая	1
30	15FMH-16035	90179-08M06	NUT		1
31	15FMH-16036	6E7-45560-01	GEAR 1 (27T)	шестерня передней передачи	1
32	15FMH-16038	6E7-45571-00	GEAR 2 (27T)	шестерня задней передачи	1
33	15FMH-16039		SHIM (T: 0.05mm)	шайба регулировочная	1
33		626-45577-00-01	SHIM (T: 0.10mm)	шайба регулировочная	1
33		626-45577-00-03	SHIM (T: 0.20mm)	шайба регулировочная	1
33		626-45577-00-05	SHIM (T: 0.50mm)	шайба регулировочная	1
34	15FMH-16040	90201-17682	WASHER, PLATE		1
35	15FMH-16041	683-45611-00	SHAFT, PROPELLER	гребной вал	1
36	15FMH-16042	650-45635-00	PLUNGER, SHIFT		1
37	15FMH-16043	682-45631-00	CLUTCH, DOG	муфта сцепления	1
38	15FMH-16044	90250-05010	PIN, STRAIGHT		1
39	15FMH-16045	648-45633-00	RING, CROSS PIN	кольцо муфты	1
40	15FMH-16046	90501-14M06	SPRING, COMPRESSION	пружина компрессионная	1
41	15FMH-16047	683-45361-02-4D	CAP, LOWER CASING	стакан редуктора	1
42	15FMH-16048	93306-00501	BEARING (B6005)		1
43	15FMH-16049	93315-317U2	BEARING		1
44	15FMH-16050	93101-17054	OIL SEAL		2
45	15FMH-16051	93210-57M09	O-RING		1
46	15FMH-16052	93210-56M80	O-RING		1
47	15FMH-16053	97095-06020	BOLT		2
48		92995-06600	WASHER		2

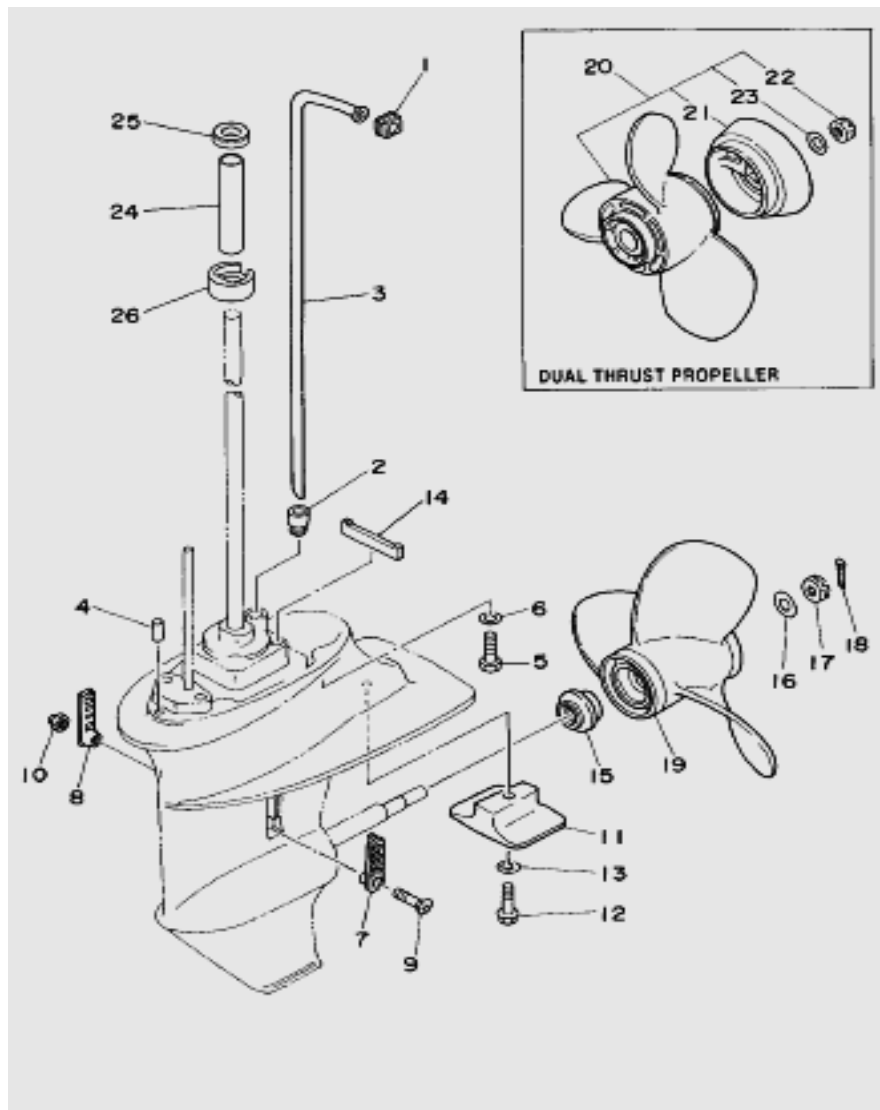

1	15FMH-17001	63V-44365-10	DAMPER, WATER SEAL		1
2	15FMH-17002	63V-44368-00	RUBBER, WATER SEAL 4		1
3	15FMH-17003S	63V-44361-01	TUBE, WATER (S)	трубка охлаждения	1
4	15FMH-17004	93604-12M07	PIN, DOWEL		2
5	15FMH-17005	97075-08030	BOLT		4
6		92995-08600	WASHER		
7	15FMH-17006	6G1-45214-00	COVER, WATER INLET		1
8	15FMH-17007	63V-45215-00	COVER, WATER INLET		1
9	15FMH-17008	90152-05M04	SCREW, COUNTERSUNK		1
10	15FMH-17007-1	90185-05002	NUT, SELF-LOCKING		1
11	15FMH-17010	61N-45251-01	ANODE		1
12	15FMH-17011	95895-06030	BOLT, FLANGE		1
13	15FMH-17012	92990-06300	WASHER, INTERNAL TOOTH		1
14	15FMH-17013	63V-45375-00	DAMPER, SEAL		1
15	15FMH-17014	6E7-45987-01	SPACER		1
16	15FMH-17015	90201-10M01	WASHER, PLATE		1
17	15FMH-17016	90171-10M01	NUT, CASTLE		1
18	15FMH-17017	91490-30020	PIN, COTTER		1
19	15FMH-17018B	63V-45945-00-EL	PROPELLER (3x9-1/4"x9"-J)		1
21		6E7-45986-00	RING, DEFLECTOR		1
22		90171-10M07	NUT, CASTLE		1
23		90201-10M02	WASHER, PLATE		1

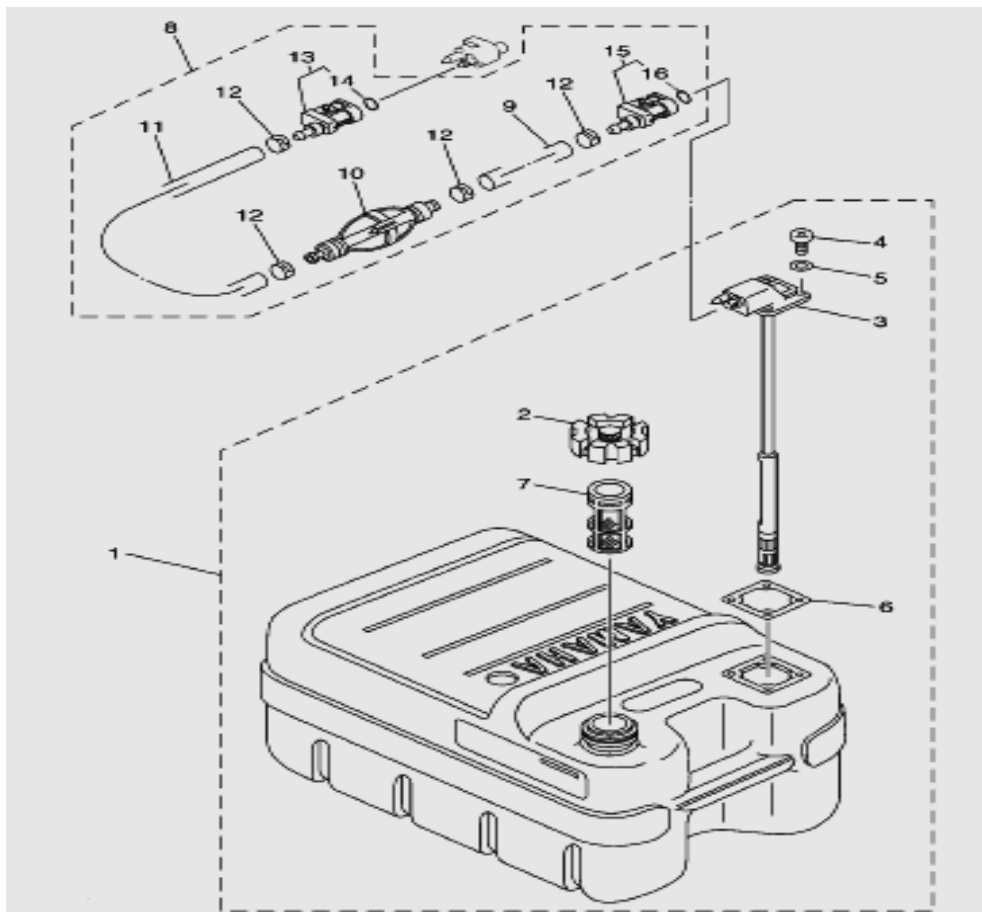

1	15FMH-18000	6YJ-24201-00	FUEL TANK ASSY (24L)		1
***	15FMH-18001				1
2	15FMH-18003	6YJ-24610-01	CAP ASSY		1
3	15FMH-18011	6YJ-24260-00	FUEL METER ASSY		1
4	15FMH-18024	98586-05016	SCREW, PAN HEAD		4
5	15FMH-18025	6Y1-24329-00	SEAL		4
6	15FMH-18026		GASKET, FUEL METER		
	15FMH-18028		STRAINER		
8	15FMH-18028		FUEL PIPE COMP. 1	топл. шланг в сборе	1
	15FMH-18088		FUEL PIPE JOINT COMP. 2		